

CHV180 Series frequency Inverter special for elevator Operation Manual



- Thank you very much for your buying CHV180 series frequency inverter special for elevator.
- Before use, please read this manual thoroughly to ensure proper usage. Keep this manual at an easily accessible place so that can refer anytime as necessary.

Safety Precautions

Please read this operation manual carefully before installation, operation, maintenance or inspection.

In this manual, the safety precautions were sorted to "WARNING" or "CAUTION".



WARNING

Indicates a potentially hazardous situation which, if not avoided, will result in death or serious injury.



CAUTION

Indicates a potentially hazardous situation which, if not avoided, will result in minor or moderate injury and physical damage. This sign is also used for alert of any un-safety operation.

In some cases, the contents of "CAUTION" could cause serious accident. Please follow these important precautions in any situation.

★ **NOTE** is the necessary step to ensure the proper operation.

Warning Marks were shown on the front keypad of inverters.

Please follow these indications when using the inverter.

WARNING

- **May cause injury or electric shock.**
- **Please follow the instructions in the manual before installation or operation.**
- **Disconnect all power line before opening front cover of unit. Wait at least 5 minute until DC Bus capacitors discharge.**
- **Use proper grounding techniques.**
- **Never connect AC power to output UVW terminals**

TABLE OF CONTENTS

TABLE OF CONTENTS	II
LIST OF FIGURES	IV
1. INTRODUCTION	1
1.1 Technology Features	1
1.2 Description of Name Plate	2
1.3 Selection Guide	2
1.4 Parts Description	3
1.5 Description of Extension Card	4
1.6 External Dimension.....	5
2. UNPACKING INSPECTION	6
3. DISASSEMBLE AND INSTALLATION	7
3.1 Environmental Requirement	8
3.2 Installation Space.....	9
3.3 Dimensions of External Keypad.....	10
3.4 Disassembly	10
4. WIRING	12
4.1 Connections of Peripheral Devices.....	13
4.2 Terminal Configuration.....	14
4.2.1 Main Circuit Terminals (380VAC)	14
4.2.2 Control Circuit Terminals	15
4.3 Typical Wiring Diagram.....	15
4.4 Specifications of Breaker, Cable, Contactor and Reactor.....	16
4.4.1 Specifications of breaker, cable and contactor.....	16
4.4.2 Specifications of AC input/output and DC reactor	16
4.4.3 Specification of input filter and output filter	17
4.5 Wiring the Main Circuits.....	17
4.5.1 Wiring at the side of power supply	17
4.5.2 Wiring for inverter.....	18
4.5.3 Wiring at motor side of main circuit.....	19
4.5.4 Wiring of regenerative unit.....	19
4.5.5 Wiring of Common DC bus	20
4.5.6 Ground Wiring (PE).....	20
4.6 Wiring Control Circuit Terminals.....	21
4.6.1 Precautions	21
4.6.2 Control circuit terminals.....	21
4.6.3 Jumper on control board	22
4.7 Installation Guidline to EMC Compliance	22
4.7.1 General knowledge of EMC	22
4.7.2 EMC features of inverter	23
4.7.3 EMC Installation Guideline.....	23
5. OPERATION	26
5.1 Operating Keypad Description	26
5.1.1 Keypad schematic diagram.....	26
5.1.2 Button function description.....	26
5.1.3 Indicator light description	27
5.2 Operation Process	28
5.2.1 Parameter setting.....	28

5.2.2	Fault reset	29
5.2.3	Motor parameter autotune.....	29
5.2.4	Password setting.....	29
5.3	Running State	30
5.3.1	Power-on initialization	30
5.3.2	Stand-by.....	30
5.3.3	Operation	30
5.3.4	Fault	30
6.	DETAILED FUNCTION DESCRIPTION.....	32
6.1	P0 Group--Basic Function	32
6.2	P1 Group--Speed curve	37
6.3	P2 Group--Motor Parameters	44
6.4	P3 Group--Vector Control	45
6.5	P4 Group -- Encoder parameter	47
6.6	P5 Group--Input Terminals.....	48
6.7	P6 Group -- Output Terminals.....	52
6.8	P7 Group --Display Interface	57
6.9	P8 Group --Enhanced Function	61
6.10	P9 Group -- Protection Parameters	64
6.11	PA Group --Serial Communication	66
6.12	PB Group -- Distance Control	68
6.13	PE Group --Factory Setting.....	68
7.	DESCRIPTION OF CHV 180'S EXTENSION CARD	69
7.1	Description of communication card.....	69
7.2	Description of I/O extension card.....	70
7.3	Description of asynchronous motor PG card	72
7.4	Description of synchronous motor PG card	77
8.	DESCRIPTION OF DEBUGGING ELEVATOR	81
8.1	Runing and adjusting parameter.....	81
8.2	Elevator runing mode.....	82
9.	TROUBLE SHOOTING	94
9.1	Fault and trouble shooting	94
9.2	Common Faults and Solutions.....	97
10.	MAINTENANCE	98
10.1	Daily Maintenance	98
10.2	Periodic Maintenance	100
10.3	Replacement of wearing parts	100
11.	COMMUNICATION PROTOCOL	101
12.	LIST OF FUNCTION PARAMETERS	112

LIST OF FIGURES

Figure 1.1	Nameplate of inverter.	2
Figure 1.2	Parts of inverter (15kw and below).	3
Figure 1.3	Parts of inverters (18.5KW and above).	3
Figure 1.4	Dimensions (15kW and below).	5
Figure 1.5	Dimensions (18.5~30kW).	5
Figure 3.1	Relationship between output current and altitude.	8
Figure 3.2	Safety space.	9
Figure 3.3	Installation of multiple inverters.	9
Figure 3.4	Dimension of small keypad.	10
Figure 3.5	Dimension of big keypad.	10
Figure 3.6	Disassembly of plastic cover.	10
Figure 3.7	Disassembly of metal plate cover.	11
Figure 3.8	Open inverter cabinet.	11
Figure 4.1	Connections of peripheral devices.	13
Figure 4.2	Main circuit terminals (4~5.5kW).	14
Figure 4.3	Main circuit terminals (7.5~15kW).	14
Figure 4.4	Main circuit terminals (18.5~30kW).	14
Figure 4.5	Control circuit terminals.	15
Figure 4.6	Wiring diagram.	15
Figure 4.7	Wiring at input side.	18
Figure 4.8	Wiring at motor side.	19
Figure 4.9	Wiring of regenerative unit.	19
Figure 4.10	Wiring of common DC bus.	20
Figure 5.1	Keypad schematic diagram.	26
Figure 5.2	Flow chart of parameter setting.	28
Figure 6.1	Effect of carrier frequency.	35
Figure 6.2	S - curve running diagram.	38
Figure 6.3	S - curve setting sketch map description.	39
Figure 6.4	Overhaul running curve.	40
Figure 6.5	The wiring of emergency running.	41
Figure 6.6	The emergency running curve.	41
Figure 6.7	Installation sketch of forcing slow-down switch.	42
Figure 6.8	Forcing decelerating running chart.	43
Figure 6.9	PI parameter diagram.	46
Figure 6.10	Relationship between AI and corresponding setting.	52
Figure 6.11	Relationship between AO and corresponding setting.	55
Figure 6.12	Relationship between HDO and corresponding setting.	55
Figure 6.13	FDT Level diagram.	56
Figure 6.14	Frequency arriving detection diagram.	56
Figure 6.15	Motor overload protection curve.	64
Figure 6.16	Overload pre-warning schematic diagram.	65
Figure 7.1	Communication card.	69
Figure 7.2	Installation of communication card.	69
Figure 7.3	D9: Bus-connector wiring terminal.	70
Figure 7.4	RS485 wiring terminal.	70
Figure 7.5	Dimension of I/O extension card.	71
Figure 7.6	Installation of I/O extension card and PG card.	72
Figure 7.7	Installation and Dimensions of PG Card.	73
Figure 7.8	User Wiring Terminals of PG Card.	74
Figure 7.9	PG Card Wiring Diagram.	75
Figure 7.10	Wiring Diagram of Differential Output Coder.	76
Figure 7.11	Wiring Diagram of Open Collector Output Coder.	76

Figure 7.12	Wiring Diagram of Push-pull Output Coder.....	77
Figure 7.13	Wiring Diagram of PG Card Frequency-division Output.....	77
Figure 7.14	Dimension and installation of synchronous motor PG card.....	78
Figure 7.15	The PG card wire port and wire terminals.....	79
Figure 8.1	Wiring principle for Multi-step speed control.....	82
Figure 8.2	Sequence chart of running for Multi-step speed control.....	83
Figure 8.3	Wiring diagram of analog quantity mode.....	87
Figure 8.4	Wiring diagram of overhaul run mode.....	90
Figure 8.5	Sequence chart of overhaul running.....	90
Figure 8.6	Wiring diagram of emergency run.....	92
Figure 8.7	Sequence chart of emergency run.....	92

1. INTRODUCTION

1.1 Technology Features

• Input & Output

- ◆ Input Voltage Range: 380V±15%
- ◆ Input Frequency Range: 47~63Hz
- ◆ Output Voltage Range: 0~rated input voltage
- ◆ Output Frequency Range: 0~400Hz

• I/O Features

- ◆ Programmable Digital Input: Provide 6 terminals which can accept ON-OFF inputs and 4 inputs can be extended by I/O extension card.
- ◆ Programmable Analog Input: AI1 can accept input of 0 ~10V, AI2 can accept input of 0~10V or 0~20mA.
- ◆ Programmable Open Collector Output: Provide 1 output terminal. 1 output (open collector output or high speed pulse output) can be extended by I/O card.
- ◆ Relay Output: Provide 2 output terminals. 1 output can be extended by I/O extension card.
- ◆ Analog Output: 2 output terminal, 0~20 mA or 0~10 V.

• Main Control Function

- ◆ Control Mode:
Sensorless vector control (SVC), Vector control with PG (VC), V/F control.
- ◆ Overload Capacity: 60s with 150% of rated current, 10s with 180% of rated current.
- ◆ Starting Torque: 150% of rated torque at 0.5Hz (SVC);
180% of rated torque at 0Hz (VC).
- ◆ Speed Adjusting Range: 1:100 (SVC); 1:1000 (VC)
- ◆ Speed Accuracy: ± 0.5% of maximum speed (SVC); ± 0.02% of maximum speed (VC)
- ◆ Carrier Frequency: 1.0kHz~16.0kHz.
- ◆ Frequency reference source: keypad, analog input, serial communication, multi-step speed.
- ◆ Operating mode: checking, emergency, decelerating.
- ◆ Elevator control logic: Internal contracting brake, contactor control.
- ◆ Precompensation of starting moment.
- ◆ PG card: asynchronous motor PG card, synchronous motor PG card.
- ◆ Automatic Voltage Regulation (AVR): Automatically keep the output voltage stable when input voltage fluctuating.
- ◆ Up to 30 fault protections:

Introduction

Protect from over current, over voltage, under voltage, over temperature, phase failure, over load etc.

1.2 Description of Name Plate

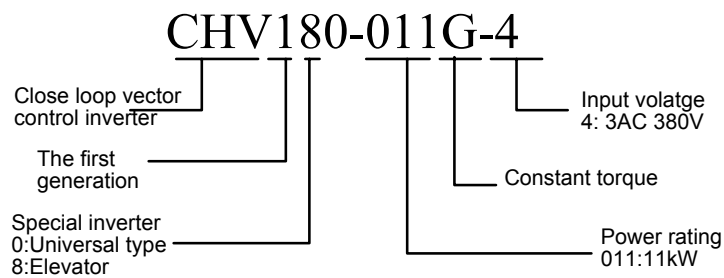
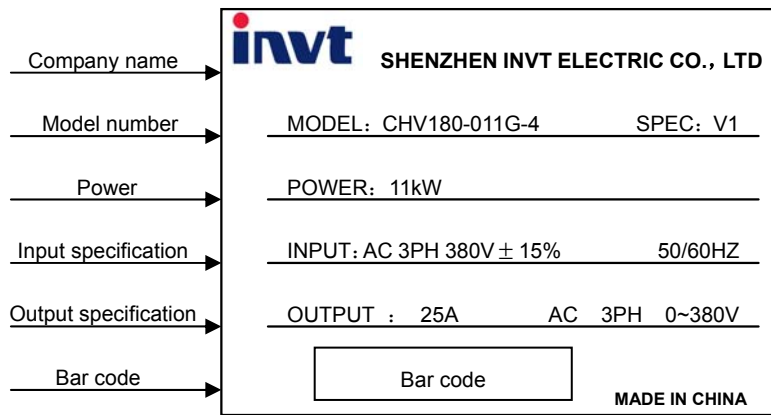

Figure 1.1 Nameplate of inverter.

1.3 Selection Guide

Model No.	Rated Power (kW)	Rated Input Current (A)	Rated Output Current (A)	Size
3AC 380V ± 15%				
CHV180-004G-4	4.0	10	9	C
CHV180-5R5G-4	5.5	15	13	C
CHV180-7R5G-4	7.5	20	17	D
CHV180-011G-4	11	26	25	D
CHV180-015G-4	15	35	32	D
CHV180-018G-4	18.5	38	37	E
CHV180-022G-4	22	46	45	E
CHV180-030G-4	30	62	60	E

1.4 Parts Description

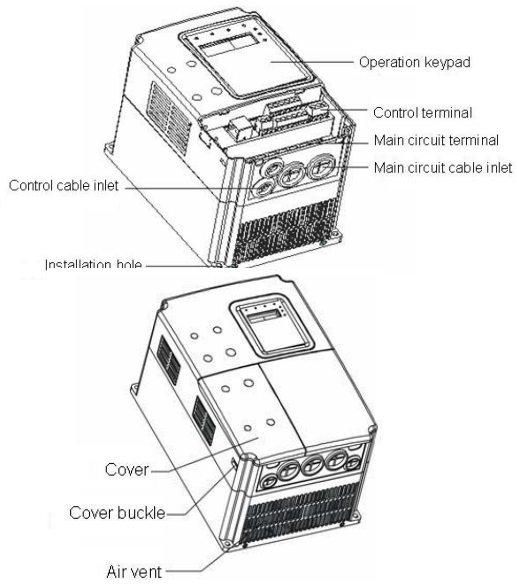

Figure 1.2 Parts of inverter (15kw and below).

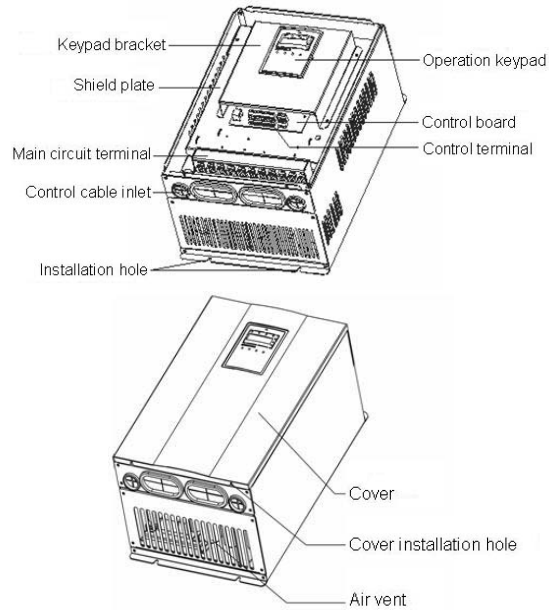

Figure 1.3 Parts of inverters (18.5KW and above).

1.5 Description of Extension Card

Thanks to advanced modular design, CHV180 series inverters can achieve specific functionality by using extension card to meet customer demand.

For details, please refer to operation manual of extension card.

Extension Card	Description
Communication Card	Offer RS232 and RS485 dual physical communication interface 1. RS232 adopts standard DB9 master seat. 2. 3-hole RS485 interface, two communication mode can be switched by short-connecting module. Receive high-speed pulse from encoder to realize high- accuracy close-loop vector control. 3. Both push-and-pull input and open-circuit collector input. 4. Offer frequency division output, the frequency-division factor can be selected by dial switch. Connect to the encoder by soft wire. Communication Card Offer RS232 and RS485 dual physical communication interface. 5. RS232 adopts standard DB9 master seat. 6. 3-hole RS485 interface, two communication mode can be switched by short-connecting module. 7. Modbus and RTU protocol.
PG Card (asynchronous motor)	Receive high-speed pulse from encoder to realize high- accuracy close-loop vector control. 1. Both push-and-pull input and open-circuit collector input. 2. Offer frequency division output, the frequency-division factor can be selected by dial switch.
PG Card (synchronous motor)	Receive high-speed pulse from encoder to realize high- accuracy close-loop vector control. 1. Compatible UVW, SIN/COS encoder special for synchronous motor. 2. Offer frequency division output, the frequency-division factor can be selected by dial switch.
I/O Extension Card	Offer more input/output terminals to enhance the external function of inverter. RS 485 port is available.

1.6 External Dimension

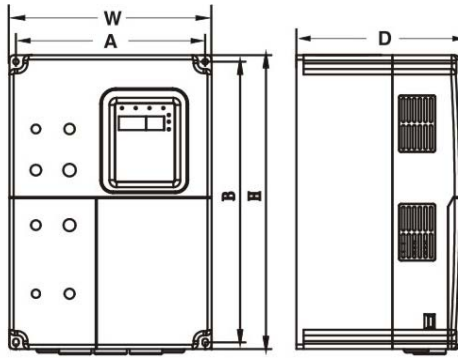

Figure1.4 Dimensions (15kW and below).

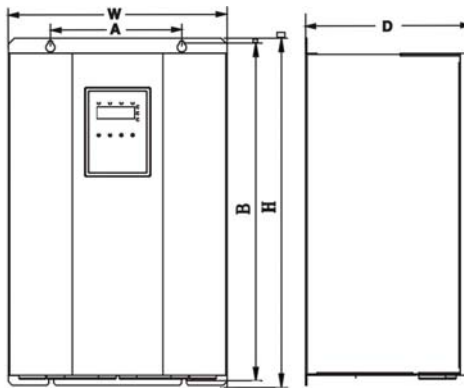

Figure 1.5 Dimensions (18.5~30kW).

Power (kW)	Size	A (mm)	B (mm)	H (mm)	W (mm)	D (mm)	Installation Hole (mm)
		Installation Dimension		External Dimension			
4.0~5.5	C	147.5	237.5	250	160	175	5.0
7.5~15	D	206	305.5	320	220	180	6.0
18.5~30	E	176	454.5	467	290	215	6.5

2. UNPACKING INSPECTION



CAUTION

- **Never install or operate any inverter that is damaged or missing components. Doing so can result in injury.**

Check the following items when unpacking the inverter,

1. Inspect the entire exterior of the Inverter to see if there are any scratches or other damage resulting from shipping.
2. Ensure there is operation manual and warranty card in the packing box.
3. Ensure the nameplate that it is you ordered.
4. Ensure the optional parts are what you need if you ordered any optional parts.

Please contact the local agent if there is any damage of inverter or optional parts.

3. DISASSEMBLE AND INSTALLATION



WARNING

- Any untrained person working on any parts/systems of inverter or any rule in the “Warning” being violated, that will cause severe injury or property damage. Only licensed person, who has been trained on design, installation, commissioning and operation of inverter, is permitted to operate this equipment.
- Input power cable must be connected tightly, and the equipment must be grounded securely.
- Even if the inverter is not in operating situation, the following terminals still have dangerous voltage:
 - Power Terminals: R, S, T
 - Motor Connection Terminals: U, V, W.
- Can not install the inverter until discharged completely after the power supply is switched off for 10 minutes.
- The section area of grounding conductor must be no less than that of power supply cable.



CAUTION

- Lift the cabinet by its base; do not lift it by holding its panel. Otherwise the main unit will fall off to result in personal injury.
- Install the inverter on top of the fireproofing material (such as, metal) to prevent fire.
- When need install two or more inverters in one cabinet, cooling fan should be applied to make sure that the air temperature is lower than 40°C. Otherwise it could cause fire or damage the device.

3.1 Environmental Requirement

3.1.1 Temperature

Environment temperature range: $-10^{\circ}\text{C} \sim +40^{\circ}\text{C}$. Inverter will be derated if ambient temperature exceeds 40°C .

3.1.2 Humidity

Less than 90% RH, without dewfall.

3.1.3 Altitude

Inverter can output the rated power when installed with altitude of lower than 1000m. It will be derated when the altitude is higher than 1000m. For details, please refer to the following figure:

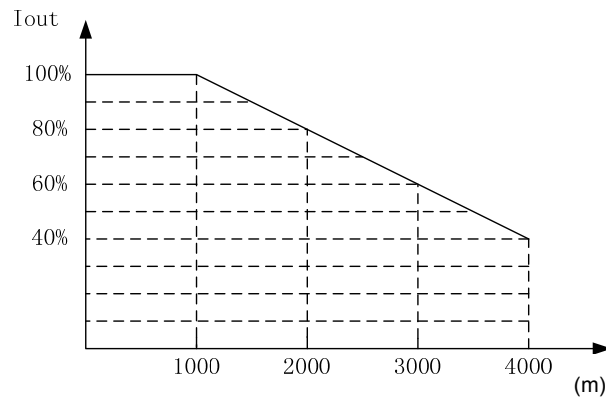

Figure 3.1 Relationship between output current and altitude.

3.1.4 Impact and Oscillation

It is not allowed that the inverter falls down or suffers from fierce impact or the inverter installed at the place that oscillation frequently.

3.1.5 Electromagnetic Radiation

Keep away from the electromagnetic radiation source.

3.1.6 Water

Do not install the inverter at the wringing or dewfall place.

3.1.7 Air Pollution

Keep away from air pollution such as dusty, corrosive gas.

3.1.8 Storage

Do not store the inverter in the environment with direct sunlight, vapor, oil fog and vibration.

3.2 Installation Space

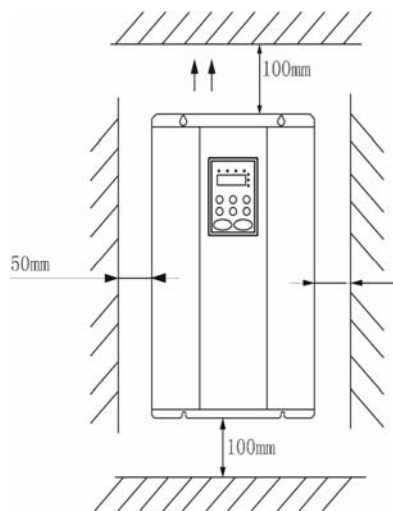

Figure 3.2 Safety space.

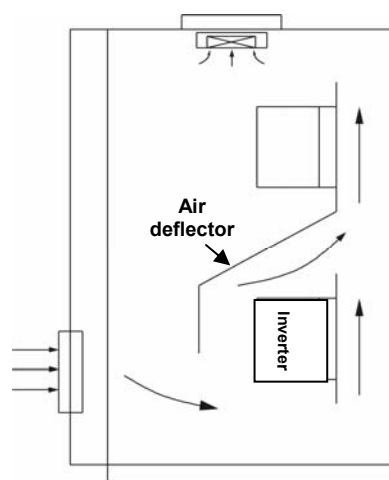

Figure 3.3 Installation of multiple inverters.

Notice: Add the air deflector when apply the up-down installation.

3.3 Dimensions of External Keypad

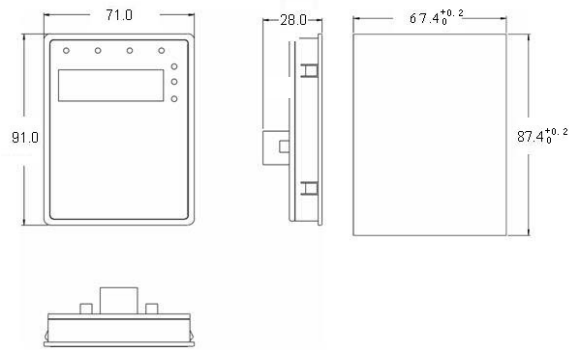

Figure 3.4 Dimension of small keypad.

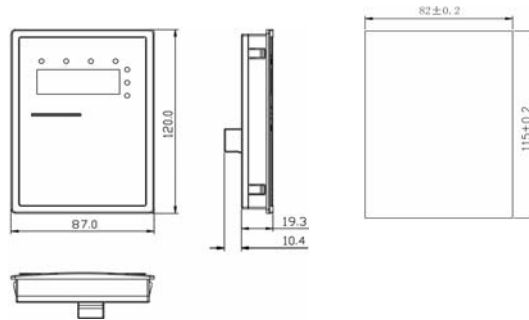

Figure 3.5 Dimension of big keypad.

3.4 Disassembly

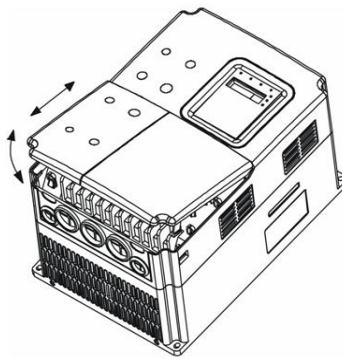

Figure 3.6 Disassembly of plastic cover.

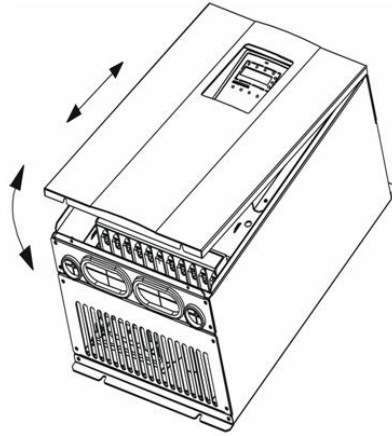

Figure 3.7 Disassembly of metal plate cover.

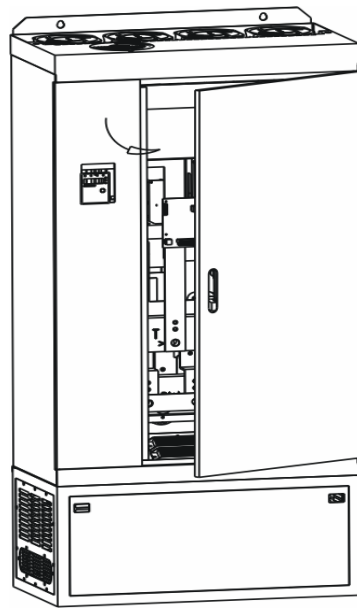

Figure 3.8 Open inverter cabinet.

4. WIRING



WARNING

- Wiring must be performed by an authorized person qualified in electrical work.
- Do not test the insulation of cable that connects the inverter with high-voltage insulation testing devices.
- Can not install the inverter until discharged completely after the power supply is switched off for 10 minutes.
- Be sure to ground the ground terminal.
Ground to 10Ω or less.
Otherwise, an electric shock or fire can occur.
- Connect input terminals (R, S, T) and output terminals (U, V, W) correctly.
Otherwise it will cause damage the inside part of inverter.
- Do not wire and operate the inverter with wet hands.
Otherwise there is a risk of electric shock.



CAUTION

- Check to be sure that the voltage of the main AC power supply satisfies the rated voltage of the Inverter.
Injury or fire can occur if the voltage is not correct.
- Connect power supply cables and motor cables tightly.

4.1 Connections of Peripheral Devices

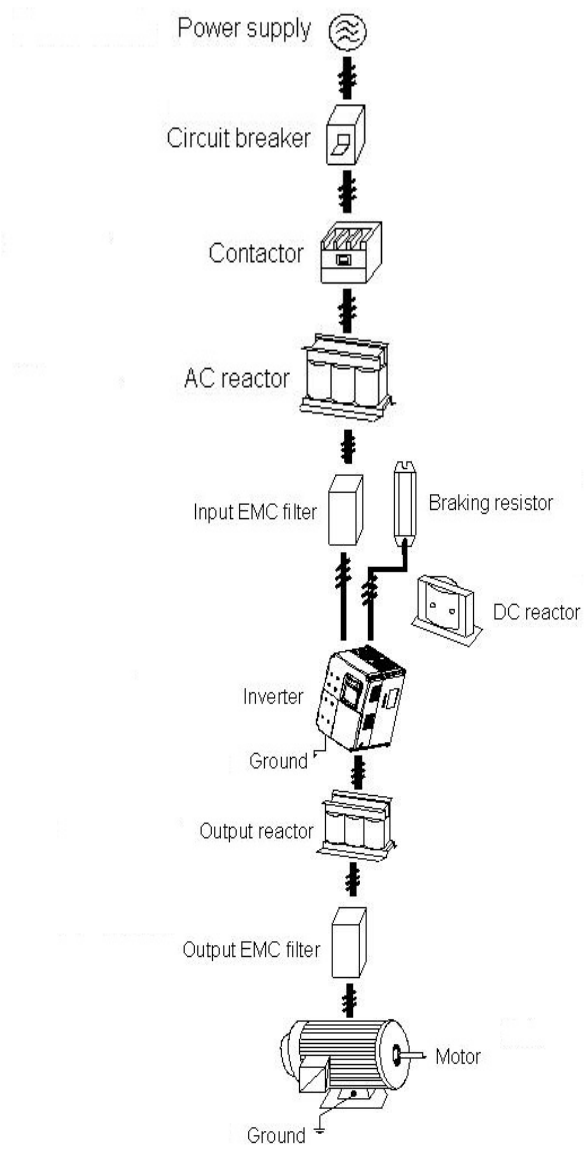

Figure 4.1 Connections of peripheral devices.

4.2 Terminal Configuration

4.2.1 Main Circuit Terminals (380VAC)

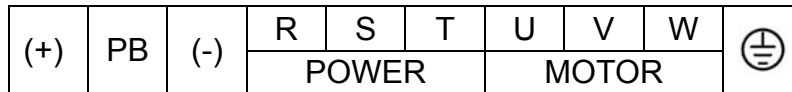

Figure 4.2 Main circuit terminals (4~5.5kW).

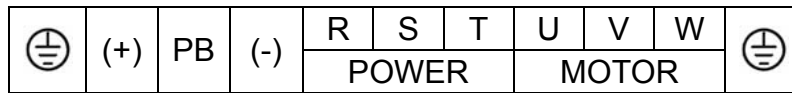

Figure 4.3 Main circuit terminals (7.5~15kW).

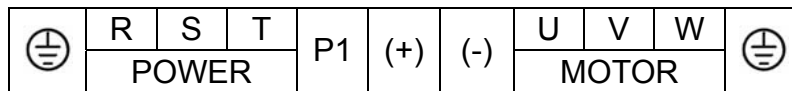



Figure 4.4 Main circuit terminals (18.5~30kW).

Main circuit terminal functions are summarized according to the terminal symbols in the following table. Wire the terminal correctly for the desired purposes.

Terminal	Description
R、S、T	Terminals of 3 phase AC input
(+)、(-)	Spare terminals of external braking unit
(+)、PB	Spare terminals of external braking resistor
P1、(+)	Spare terminals of external DC reactor
(-)	Terminal of negative DC bus
U、V、W	Terminals of 3 phase AC output
	Terminal of ground

4.2.2 Control Circuit Terminals

S1	S2	S3	S4	S5	HD11	GND	AI1	AI2	+10V	R01A	R01B	R01C
+24V	PW	COM	Y1	CME	COM	HDO	AO1	GND	PE	R02A	R02B	R02C

Figure 4.5 Control circuit terminals.

4.3 Typical Wiring Diagram

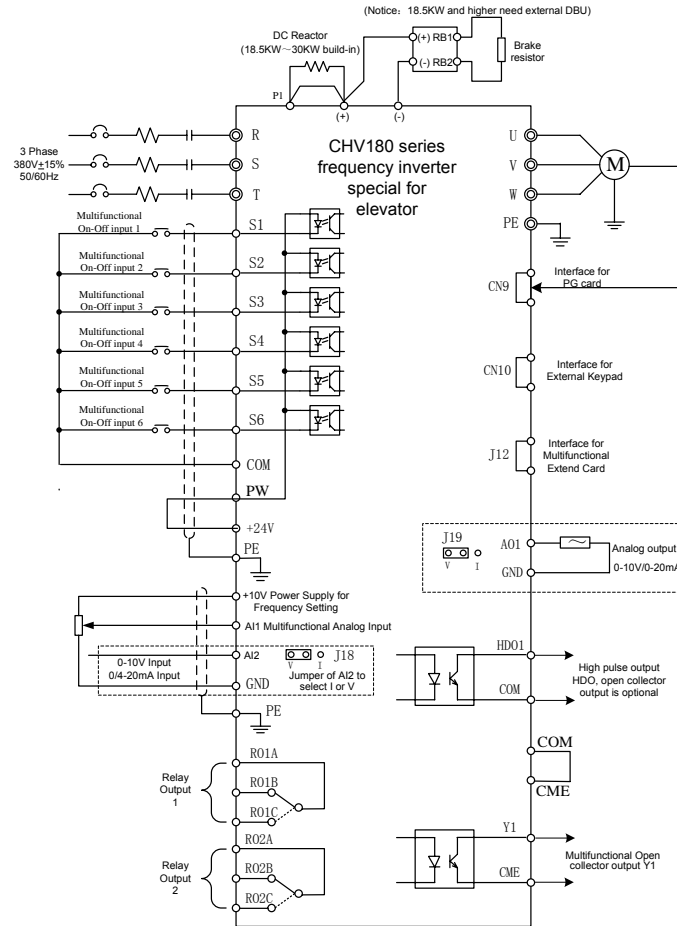

Figure4. 6 Wiring diagram.

Notice:

1. Inverters between 18.5KW and 30KW have built-in DC reactor which is used to improve power factor.
2. The inverters below 18.5KW have build-in braking unit. If need braking, only need to install braking resistor between PB and (+).
3. For inverters above (including) 18.5KW, if need braking, should install external braking unit between (+) and (-).
4. +24V connect with PW as default setting. If user need external power supply, disconnect +24V with PW and connect PW with external power supply.

4.4 Specifications of Breaker, Cable, Contactor and Reactor

4.4.1 Specifications of breaker, cable and contactor

Model No.	Circuit breaker (A)	Input/output cable (mm ²) (Copper wire)	Rated current of contactor (A) (380V)
CHV180-004G-4	25	4	16
CHV180-5R5G-4	25	4	16
CHV180-7R5G-4	40	6	25
CHV180-011G-4	63	6	32
CHV180-015G-4	63	6	50
CHV180-018G-4	100	10	63
CHV180-022G-4	100	16	80
CHV180-030G-4	125	25	95

4.4.2 Specifications of AC input/output and DC reactor

Model No.	AC Input reactor		AC Output reactor		DC reactor	
	Current (A)	Inductance (mH)	Current (A)	Inductance (mH)	Current (A)	Inductance (mH)
3AC 380V ±15%						
CHV180-004G-4	10	1.5	10	0.6	12	6.3
CHV180-5R5G-4	15	1.0	15	0.25	23	3.6
CHV180-7R5G-4	20	0.75	20	0.13	23	3.6
CHV180-011G-4	30	0.60	30	0.087	33	2
CHV180-015G-4	40	0.42	40	0.066	33	2
CHV180-018G-4	50	0.35	50	0.052	40	1.3

CHV180-022G-4	60	0.28	60	0.045	50	1.08
CHV180-030G-4	80	0.19	80	0.032	65	0.80

4.4.3 Specification of input filter and output filter

Inverter capacity (kW)	Input filter model	Output filter model
CHV180-004G-4	NFI-010	NFO-010
CHV180-5R5G-4	NFI-020	NFO-020
CHV180-7R5G-4	NFI-020	NFO-020
CHV180-011G-4	NFI-036	NFO-036
CHV180-015G-4	NFI-036	NFO-036
CHV180-018G-4	NFI-050	NFO-050
CHV180-022G-4	NFI-050	NFO-050
CHV180-030G-4	NFI-065	NFO-065

4.5 Wiring the Main Circuits

4.5.1 Wiring at the side of power supply

- Circuit breaker

It is necessary to connect a circuit breaker which is compatible with the capacity of inverter between 3ph AC power supply and power input terminals (R, S, T). The capacity of breaker is 1.5~2 times to the rated current of inverter. For details, see <Specifications of Breaker, Cable, and Contactor>.

- Contactor

In order to cut off the input power effectively when something is wrong in the system, contactor should be installed at the input side to control the ON-OFF of the main circuit power supply.

- AC reactor

In order to prevent the rectifier damage result from the large current, AC reactor should be installed at the input side. It can also prevent rectifier from sudden variation of power voltage or harmonic generated by phase-control load.

- Input EMC filter

The surrounding device may be disturbed by the cables when the inverter is working.

EMC filter can minimize the interference. Just like the following figure.

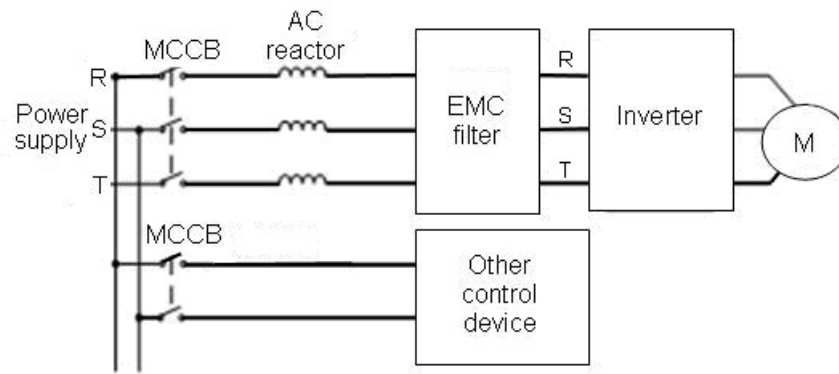

Figure4.7 Wiring at input side.

4.5.2 Wiring for inverter

- DC reactor

Inverters from 18.5kW to 30kW (380V class) have built-in DC reactor which can improve the power factor,

- Braking unit and braking resistor

- Inverters of 15KW and below have built-in braking unit. In order to dissipate the regenerative energy generated by dynamic braking, the braking resistor should be installed at (+) and PB terminals. The wire length of braking resistor should be less than 5m.

- Inverter of 18.5KW and above need connect external braking unit which should be installed at (+) and (-) terminals. The cable between inverter and braking unit should be less than 5m. The cable between braking unit and braking resistor should be less than 10m.

- The temperature of braking resistor will increase because the regenerative energy will be transformed to heat. Safety protection and good ventilation is recommended.

Notice: Be sure that the electric polarity of (+) (-) terminals is right; it is not allowed to connect (+) with (-) terminals directly, Otherwise damage or fire could occur.

4.5.3 Wiring at motor side of main circuit

- Output Reactor

When the distance between inverter and motor is more than 50m, inverter may be tripped by over-current protection frequently because of the large leakage current resulted from the parasitic capacitance with ground. And the same time to avoid the damage of motor insulation, the output reactor should be installed.

- Output EMC filter

EMC filter should be installed to minimize the leakage current caused by the cable and minimize the radio noise caused by the cables between the inverter and cable. Just see the following figure.

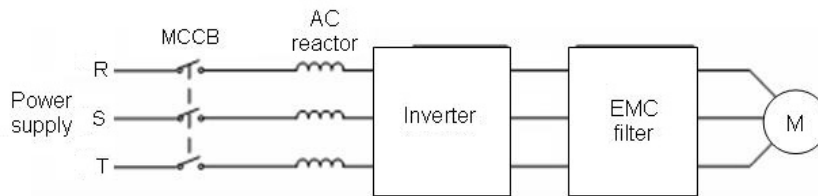

Figure 4.8 Wiring at motor side.

4.5.4 Wiring of regenerative unit

Regenerative unit is used for putting the electricity generated by braking of motor to the grid. Compared with traditional 3 phase inverse parallel bridge type rectifier unit, regenerative unit uses IGBT so that the total harmonic distortion (THD) is less than 4%. Regenerative unit is widely used for centrifugal and hoisting equipment.

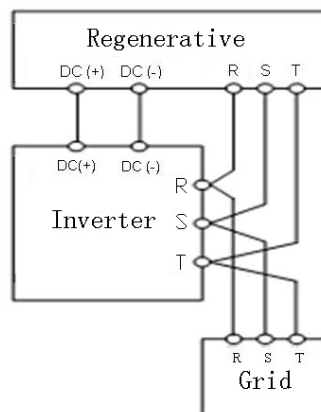

Figure 4.9 Wiring of regenerative unit.

4.5.5 Wiring of Common DC bus

Common DC bus method is widely used in the paper industry and chemical fiber industry which need multi-motor to coordinate. In these applications, some motors are in driving status while some others are in regenerative braking (generating electricity) status. The regenerated energy is automatically balanced through the common DC bus, which means it can supply to motors in driving status. Therefore the power consumption of whole system will be less compared with the traditional method (one inverter drives one motor).

When two motors are running at the same time (i.e. winding application), one is in driving status and the other is in regenerative status. In this case the DC buses of these two inverters can be connected in parallel so that the regenerated energy can be supplied to motors in driving status whenever it needs. Its detailed wiring is shown in the following figure:

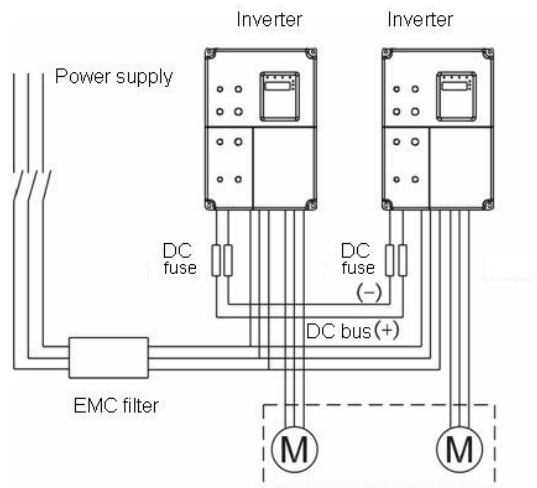

Figure 4.10 Wiring of common DC bus.

Notice: Two inverters must be the same model when connected with Common DC bus method. Be sure they are powered on at the same time.

4.5.6 Ground Wiring (PE)

In order to ensure safety and prevent electrical shock and fire, terminal PE must be grounded with ground resistance. The ground wire should be big and short, and it is better to use copper wire ($>3.5\text{mm}^2$). When multiple inverters need to be grounded, do

not loop the ground wire.

4.6 Wiring Control Circuit Terminals

4.6.1 Precautions

- Use shielded or twisted-pair cables to connect control terminals.
- Connect the ground terminal (PE) with shield wire.
- The cable connected to the control terminal should leave away from the main circuit and heavy current circuits (including power supply cable, motor cable, relay and contactor connecting cable) at least 20cm and parallel wiring should be avoided. It is suggested to apply perpendicular wiring to prevent inverter malfunction caused by external interference.

4.6.2 Control circuit terminals

Terminal	Description
S1~S6	ON-OFF signal input, optical coupling with PW and COM. Input voltage range: 9~30V Input impedance: 3.3k Ω
PW	External power supply. +24V terminal is connected to PW terminal as default setting. If user need external power supply, disconnect +24V terminal with PW terminal and connect PW terminal with external power supply.
+24V	Provide output power supply of +24V. Maximum output current: 150mA
COM	Common ground terminal for digital signal and +24V (or external power supply).
AI1	Analog input, 0~10V Input impedance: 10k Ω
AI2	Analog input, 0~10V/ 0~20mA, switched by J18. Input impedance:10k Ω (voltage input) / 250 Ω (current input)
GND	Common ground terminal of analog signal and +10V. GND must isolated from COM.
Y1 (Y2)	Open collector output terminal, the corresponding common ground terminal is CME. External voltage range: 0~24V Output current range: 0~50mA
CME	Common terminal of open collector output
+10V	Supply +10V for inverter.
HDO	High speed pulse output terminal. The corresponding common ground terminal is COM. Output frequency range: 0~50 kHz

Terminal	Description
AO1 (AO2)	Provide voltage or current output which can be switched by J19. Output range: 0~10V/ 0~20mA
PE	Ground Terminal.
RO1A、RO1B、 RO1C	RO1 relay output: RO1A—common; RO1B—NC; RO1C—NO. Contact capacity: AC 250V/3A, DC 30V/1A.
RO2A、RO2B、 RO2C	RO2 relay output: RO2A—common; RO2B—NC; RO2C—NO. Contact capacity: AC 250V/3A, DC 30V/1A.
RO3A、RO3B、 RO3C	RO3 relay output: RO3A—common; RO3B—NC; RO3C—NO. Contact capacity: AC 250V/3A, DC 30V/1A.

4.6.3 Jumper on control board

Jumper	Description
J2, J4, J5, J13, J14	It is prohibited to be connected together, otherwise it will cause inverter malfunction.
J18	Switch between (0~10V) voltage input and (0~20mA) current input. V connect to GND means voltage input; I connect to GND means current input.
J19	Switch between (0~10V) voltage output and (0~20mA) current output. V connect to OUT means voltage output; I connect to OUT means current output.

4.7 Installation Guideline to EMC Compliance

4.7.1 General knowledge of EMC

EMC is the abbreviation of electromagnetic compatibility, which means the device or system has the ability to work normally in the electromagnetic environment and will not generate any electromagnetic interference to other equipments.

EMC includes two subjects: electromagnetic interference and electromagnetic anti-jamming.

According to the transmission mode, Electromagnetic interference can be divided into two categories: conducted interference and radiated interference.

Conducted interference is the interference transmitted by conductor. Therefore, any conductors (such as wire, transmission line, inductor, capacitor and so on) are the transmission channels of the interference.

Radiated interference is the interference transmitted in electromagnetic wave, and the

energy is inverse proportional to the square of distance.

Three necessary conditions or essentials of electromagnetic interference are: interference source, transmission channel and sensitive receiver. For customers, the solution of EMC problem is mainly in transmission channel because of the device attribute of disturbance source and receiver can not be changed.

4.7.2 EMC features of inverter

Like other electric or electronic devices, inverter is not only an electromagnetic interference source but also an electromagnetic receiver. The operating principle of inverter determines that it can produce certain electromagnetic interference noise. And the same time inverter should be designed with certain anti-jamming ability to ensure the smooth working in certain electromagnetic environment. The following is its EMC features:

- Input current is non-sine wave. The input current includes large amount of high-harmonic waves that can cause electromagnetic interference, decrease the grid power factor and increase the line loss.
- Output voltage is high frequency PWM wave, which can increase the temperature rise and shorten the life of motor. And the leakage current will also increase, which can lead to the leakage protection device malfunction and generate strong electromagnetic interference to influence the reliability of other electric devices.
- As the electromagnetic receiver, too strong interference will damage the inverter and influence the normal using of customers.
- In the system, EMS and EMI of inverter coexist. Decrease the EMI of inverter can increase its EMS ability.

4.7.3 EMC Installation Guideline

In order to ensure all electric devices in the same system to work smoothly, this section, based on EMC features of inverter, introduces EMC installation process in several aspects of application (noise control, site wiring, grounding, leakage current and power supply filter). The good effective of EMC will depend on the good effective of all of these five aspects.

4.7.3.1 Noise control

All the connections to the control terminals must use shielded wire. And the shield layer of the wire must ground near the wire entrance of inverter. The ground mode is 360 degree annular connection formed by cable clips. It is strictly prohibitive to connect the

twisted shielding layer to the ground of inverter, which greatly decreases or loses the shielding effect.

Connect inverter and motor with the shielded wire or the separated cable tray. One side of shield layer of shielded wire or metal cover of separated cable tray should connect to ground, and the other side should connect to the motor cover. Installing an EMC filter can reduce the electromagnetic noise greatly.

4.7.3.2 Site wiring

Power supply wiring: the power should be separated supplied from electrical transformer. Normally it is 5 core wires, three of which are fire wires, one of which is the neutral wire, and one of which is the ground wire. It is strictly prohibitive to use the same line to be both the neutral wire and the ground wire

Device categorization: there are different electric devices contained in one control cabinet, such as inverter, filter, PLC and instrument etc, which have different ability of emitting and withstanding electromagnetic noise. Therefore, it needs to categorize these devices into strong noise device and noise sensitive device. The same kinds of device should be placed in the same area, and the distance between devices of different category should be more than 20cm.

Wire Arrangement inside the control cabinet: there are signal wire (light current) and power cable (strong current) in one cabinet. For the inverter, the power cables are categorized into input cable and output cable. Signal wires can be easily disturbed by power cables to make the equipment malfunction. Therefore when wiring, signal cables and power cables should be arranged in different area. It is strictly prohibitive to arrange them in parallel or interlacement at a close distance (less than 20cm) or tie them together. If the signal wires have to cross the power cables, they should be arranged in 90 angles. Power input and output cables should not either be arranged in interlacement or tied together, especially when installed the EMC filter. Otherwise the distributed capacitances of its input and output power cable can be coupling each other to make the EMC filter out of function.

4.7.3.3 Ground

Inverter must be ground safely when in operation. Grounding enjoys priority in all EMC methods because it does not only ensure the safety of equipment and persons, but also is the simplest, most effective and lowest cost solution for EMC problems.

Grounding has three categories: special pole grounding, common pole grounding and series-wound grounding. Different control system should use special pole grounding, and different devices in the same control system should use common pole grounding,

and different devices connected by same power cable should use series-wound grounding.

4.7.3.2 Leakage Current

Leakage current includes line-to-line leakage current and over-ground leakage current. Its value depends on distributed capacitances and carrier frequency of inverter. The over-ground leakage current, which is the current passing through the common ground wire, can not only flow into inverter system but also other devices. It also can make leakage current circuit breaker, relay or other devices malfunction. The value of line-to-line leakage current, which means the leakage current passing through distributed capacitors of input output wire, depends on the carrier frequency of inverter, the length and section areas of motor cables. The higher carrier frequency of inverter, the longer of the motor cable and/or the bigger cable section area, the larger leakage current will occur.

Countermeasure:

Decreasing the carrier frequency can effectively decrease the leakage current. In the case of motor cable is relatively long (longer than 50m), it is necessary to install AC reactor or sinusoidal wave filter at the output side, and when it is even longer, it is necessary to install one reactor at every certain distance.

4.7.3.5 EMC Filter

EMC filter has a great effect of electromagnetic decoupling, so it is preferred for customer to install it.

For inverter, noise filter has following categories:

- Noise filter installed at the input side of inverter;
- Install noise isolation for other equipment by means of isolation transformer or power filter.

4.7.4 If user install inverter and EMI filter according to the installation guideline, we believe inverter system comply with following compliance.

- EN61000-6-4
- EN61000-6-3
- EN61800-3

5. OPERATION

5.1 Operating Keypad Description

5.1.1 Keypad schematic diagram

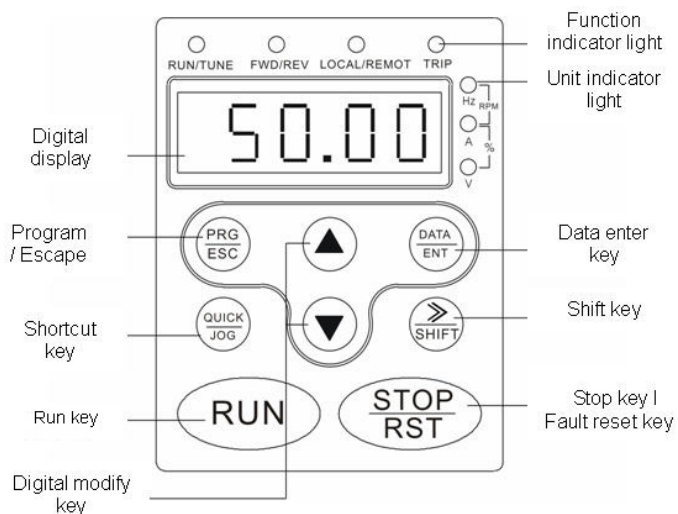



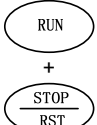

Figure 5.1 Keypad schematic diagram.

5.1.2 Button function description

Button	Name	Description
	Programming Key	Entry or escape of first-level menu.
	Enter Key	Progressively enter menu and confirm parameters.
	UP Increment Key	Progressively increase data or function codes.
	DOWN Decrement Key	Progressive decrease data or function codes.
	Shift Key	In parameter setting mode, press this button to select the bit to be modified. In other modes, cyclically displays parameters by right shift

Button	Name	Description
	Run Key	Start to run the inverter in keypad control mode.
	STOP/RESET Key	In running status, restricted by P7.04, can be used to stop the inverter. When fault alarm, can be used to reset the inverter without any restriction.
	Shortcut Key	Determined by Function Code P7.03: 0: Jog operation 1: Switch between forward and reverse 2: Clear the [UP/DOWN] settings. 3: Quick debugging mode1 (by menu) 4: Quick debugging mode2 (by latest order) 5: Quick debugging mode3 (by non-factory setting parameters)
	Combination Key	Pressing the [RUN] and [STOP/RESET] at the same time can achieve inverter coast to stop.

5.1.3 Indicator light description

5.1.3.1 Function Indicator Light Description

Function indicator	Description
[RUN/TUNE]	Extinguished: stop status Flickering: parameter autotuning status Light on: operating status
[FWD/REV]	Extinguished: forward operation Light on: reverse operation.
[LOCAL/REMOT]	Extinguished: keypad control Flickering: terminal control Light on: communication control
[TRIP]	Extinguished: normal operation status Flickering: overload pre-warning status

5.1.3.2 Unit Indicator Light Description

Unit indicator	Description
Hz	Frequency unit
A	Current unit
V	Voltage unit
RPM	Rotating speed unit
%	Percentage

5.1.3.3 Digital Display

Have 5 digit LED , which can display all kinds of monitoring data and alarm codes such as reference frequency, output frequency and so on.

5.2 Operation Process

5.2.1 Parameter setting

Three levels of menu are:

- Function code group (first-level);
- Function code (second-level);
- Function code value (third-level).

Remarks:

Press both the **PRG/ESC** and the **DATA/ENT** can return to the second-class menu from the third-class menu. The difference is: pressing **DATA/ENT** will save the set parameters into the control panel, and then return to the second-class menu with shifting to the next function code automatically; while pressing **PRG/ESC** will directly return to the second-class menu without saving the parameters, and keep staying at the current function code.

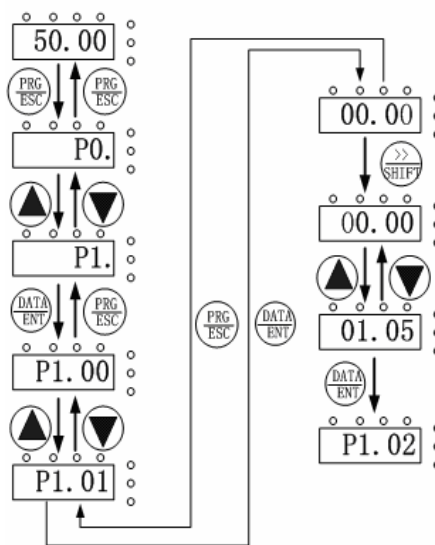

Figure 5.2 Flow chart of parameter setting.

Under the third-class menu, if the parameter has no flickering bit, it means the function code cannot be modified. The possible reasons could be:

- This function code is not modifiable parameter, such as actual detected

- parameter, operation records and so on;
- This function code is not modifiable in running status, but modifiable in stop status.

5.2.2 Fault reset

If the inverter has fault, it will prompt the related fault information. User can use **STOP/RST** or according terminals determined by P5 Group to reset the fault. After fault reset, the inverter is at stand-by state. If user does not reset the inverter when it is at fault state, the inverter will be at operation protection state, and can not run.

5.2.3 Motor parameter autotune

If “Sensorless Vector Control” or “Vector Control with PG” mode is chosen, motor nameplate parameters must be input correctly as the autotuning is based on it. The performance of vector control depends on the parameters of motor strongly, so to achieve excellent performance, firstly must obtain the parameter of motor exactly.

The procedure of motor parameter autotuning is as follows:

Firstly, choose keypad command as the run command source (P0.01).

And then input following parameters according to the actual motor parameters:

P2.01: motor rated frequency;

P2.02: motor rated speed;

P2.03: motor rated voltage;

P2.04: motor rated current

P2.05: motor rated power.

Notice: the motor should be uncoupled with its load; otherwise, the motor parameters obtained by autotuning may be not correct.

Set P0.17 to be 1, and for the detail process of motor parameter autotuning, please refer to the description of Function Code P0.17. And then press **RUN** on the keypad panel, the inverter will automatically calculate following parameter of the motor:

P2.06: motor stator resistance;

P2.07: motor rotor resistance;

P2.08: motor stator and rotor inductance;

P2.09: motor stator and rotor mutual inductance;

P2.10: motor current without load;

then motor autotuning is finished.

5.2.4 Password setting

CHV series inverter offers user's password protection function. When P7.00 is set to be nonzero, it will be the user's password, and After exiting function code edit mode, it will become effective after 1 minute. If pressing the **PRG/ESC** again to try to access the function code edit mode, “----”will be displayed, and the operator must input correct

user's password, otherwise will be unable to access it.

If it is necessary to cancel the password protection function, just set P7.00 to be zero.

Notice: Password is not effective for parameters in shortcut menu.

5.3 Running State

5.3.1 Power-on initialization

Firstly the system initializes during the inverter power-on, and LED displays "8888". After the initialization is completed, the inverter is on stand-by status.

5.3.2 Stand-by

At stop or running status, parameters of multi-status can be displayed. Whether or not to display this parameter can be chosen through Function Code P7.06 (Running status display selection) and P7.07 (Stop status display selection) according to binary bits, the detailed description of each bit please refer the function code description of P7.06 and P7.07.

In stop status, there are fourteen parameters which can be chosen to display or not. They are: reference frequency, DC bus voltage, Input-Output terminal status, open collector output status, PID setting, PID feedback, AI1 voltage, AI2 voltage, AI3 voltage/current, AI4 voltage, HDI1 frequency, HDI2 frequency, step number of simple PLC or multi-step speed, length value. Whether or not to display can be determined by setting the corresponding binary bit of P7.07. Press the **»/SHIFT** to scroll through the parameters in right order . Press **DATA/ENT** + **QUICK/JOG** to scroll through the parameters in left order.

5.3.3 Operation

In running status, there are twenty one running parameters which can be chosen to display or not. They are: running frequency, reference frequency, DC bus voltage, output voltage, output current, rotating speed, output power, output torque, PID setting, PID feedback, ON-OFF input status, open collector output status, length value, count value, step number of PLC or multi-step speed, AI1 voltage, AI2 voltage, AI3 voltage/current, AI4 voltage, HDI1 frequency, HDI2 frequency. Whether or not to display can be determined by setting the corresponding binary bit of P7.06. Press the **»/SHIFT** to scroll through the parameters in right order . Press **DATA/ENT** + **QUICK/JOG** to scroll through the parameters in left order.

5.3.4 Fault

In fault status, inverter will display parameters of STOP status besides parameters of

fault status. Press the **»/SHIFT** to scroll through the parameters in right order . Press **DATA/ENT** + **QUICK/JO** to to scroll through the parameters in left order.

6. DETAILED FUNCTION DESCRIPTION

6.1 P0 Group--Basic Function

Function Code	Name	Description	Setting Range	Factory Setting
P0.00	Speed control mode	0:Sensorless vector control 1:Vector control With PG 2:V/F control	0~2	1

0: Sensorless vector control: It is widely used for the low-end elevator which requires lower accuracy or used for debugging.

1: Vector control with PG: Close-loop vector control, requires the client to add the speed feedback equipment. Therefore it is suitable for the high-grade elevator requiring high speed control accuracy and speedy dynamic response.

2: V/F control: It is suitable for the low-end elevator which requires lower accuracy or used for debugging.

Notice:

- **Inverter can drive only one motor when P0.00 is set to be 0 or 1. When P0.00 is set to be 2, inverter can drive multi motors.**
- **The autotuning of motor parameters must be accomplished properly when P0.00 is set to be 0 or 1.**
- **In order to achieve better control characteristic, the parameters of speed regulator (P3.00~P3.05) must be adjusted according to actual situation when P0.00 is set to be 0 or 1.**

Function Code	Name	Description	Setting Range	Factory Setting
P0.01	Run command source	0: Keypad (LED extinguished) 1: Terminal (LED flickering) 2: Communication (LED lights on)	0~2	1

The control commands of inverter include: start, stop, up, down, fault reset and so on.

0: Keypad (LED extinguished);

Both **RUN** and **STOP/RST** key are used for running command control. If Multifunction key **QUICK/JOG** is set as FWD/REV switching function (P7.03 is set to be 1), it will be used to change the rotating orientation. **In running status, pressing **RUN** and **STOP/RST** in the same time will cause the inverter coast to stop.**

1: Terminal (LED flickering)

The operation, including up, down etc. can be controlled by multifunctional input terminals.

2: Communication (LED lights on)

The operation of inverter can be controlled by host through communication.

Function Code	Name	Setting Range	Factory Setting
P0.02	Elevator rating speed	0.100~4.000	1.500m/s

P0.02 is the rating speed on the elevator nameplate, the setting value should be less than the elevator rating speed. The relationship of the inverter's output frequency and the elevator's running line speed is linear. The expression is as follow:

$$f = \frac{60ikf_N}{3.14Dn_N} v$$

Thereinto, **f** represents output frequency of elevator, **v** represents running line speed of elevator, **D** represents diameter of tractor (P2.01), **i** represents ratio of deceleration (P2.02), **k** represents ratio of hanging (P2.03), f_N represents rating frequency of motor (P2.05), n_N represents rating rotate speed of motor (P2.06).

Notice: The speed of elevator is limited by P0.02, and the maximum output frequency of inverter is limited by P0.04, so the maximum running line speed of elevator is limited by both P0.02 and P0.04.

Function Code	Name	Description	Setting Range	Factory Setting
P0.03	Speed command source	0: Keypad 1: AI1 2: AI2 3. Multi-Step speed 4. Communication 5. Reservation	0~5	3

0: Keypad: Please refer to description of P0.05.

1: AI1

2: AI2

The reference speed is set by analog input. AI1 is 0~10V voltage input terminal, while AI2 is 0~10V voltage input or 0(4) ~ 20mA current input.

3: Multi-steps speed

The reference frequency is determined by P1 group and P5 group. The selection of

Detailed Function Description

steps is determined by combination of multi-step speed terminals.

Notice:

- **Multi-step speed mode will enjoy priority in setting reference frequency if P0.03 is not set to be 3. In this case, only step 1 to step 7 are available.**
- **If P0.03 is set to be 3, step 0 to step 7 can be realized.**
- **Jog has highest priority.**

4: Communication

The reference frequency is set through RS485. For details, please refer to operation manual of communication card.

5: Reservation

Notice:

- **When P0.03 is set to be 1 or 2, the process of speed-up and speed-down is decided by exterior controller, and P1.08~P1.13 are invalid.**
- **Speed command and analog weighing signal input can't select the same analog input channel.**

Function Code	Name	Description	Setting Range	Factory Setting
P0.04	Maximum frequency	10~400.00Hz	10.0~400.00	50.00Hz

Notice:

- **The frequency reference should not exceed maximum frequency.**
- **Actual acceleration time and deceleration time are determined by maximum frequency.**

Function Code	Name	Setting Range	Factory Setting
P0.05	Keypad reference speed	0.00 ~ P0.02	1.500m/s

When P0.03 is set to be 0, this parameter is the initial value of inverter reference speed.

Function Code	Name	Description	Setting Range	Factory Setting
P0.06	Running direction selection	0: Forward 1: Reverse 2: Forbid reverse	0~2	0

Notice:

- **The rotation direction of motor is corresponding to the wiring of motor.**
- **When the factory setting is restored (P0.09 is set to be 1), the rotation**

direction of motor may be changed. Please be cautious to use.

- If P0.06 is set to 2, user can not change rotation direction of motor by **QUICK/JOG** or terminal.

Function Code	Name	Description	Setting Range	Factory Setting
P0.07	Carrier frequency	1.0~16.0kHz	1.0~16.0	Depend on model

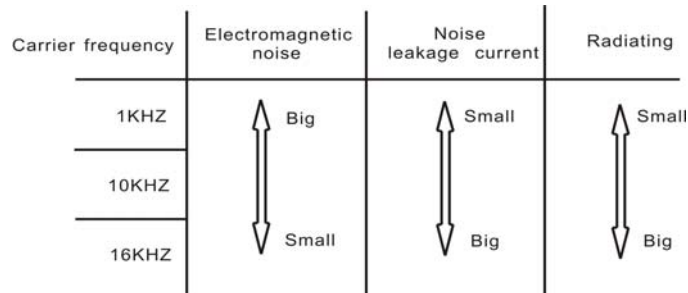

Figure 6.1 Effect of carrier frequency.

Carrier frequency / Model	Highest Carrier Frequency(kHz)	Lowest Carrier Frequency(kHz)	Factory Setting (kHz)
G Model: 4kW~11kW	16	1	8
G Model: 15kW~30kW	8	1	4

Carrier frequency will affect the noise of motor and the EMI of inverter.

If the carrier frequency is increased, it will cause better current wave, less harmonic current and lower noise of motor.

Notice:

- **The factory setting is optimal in most cases. Modification of this parameter is not recommended.**
- **If the carrier frequency exceeds the factory setting, the inverter must be derated because the higher carrier frequency will cause more switching loss, higher temperature rise of inverter and stronger electromagnetic interference.**
- **If the carrier frequency is lower than the factory setting, it is possible to cause less output torque of motor and more harmonic current.**

Detailed Function Description

Function Code	Name	Description	Setting Range	Factory Setting
P0.08	Motor parameters autotuning	0: No action 1: Rotation autotuning 2: Static autotuning	0~2	0

0: No action: Forbidding autotuning.

1: Rotation autotuning:

- Do not connect any load to the motor when performing autotuning and ensure the motor is in static status.
- Input the nameplate parameters of motor (P2.04~P2.08) correctly before performing autotuning. Otherwise the parameters detected by autotuning will be incorrect; it may influence the performance of inverter.
- The operation process is as follow:
 - a. Set P0.08 to be 1 then press the **DATA/ENT**, LED will display “-TUN-” and flickers. During “-TUN-” is flickering, press the **PRG/ESC** to exit autotuning.
 - b. Press the **RUN** to start the autotuning. LED will display “TUN-0”.
 - c. After a few seconds the motor will start to run. LED will display “TUN-1” and “RUN/TUNE” light will flicker.
 - d. After a few minutes, LED will display “-END-”. That means the autotuning is finished and return to the stop status.
 - e. During the autotuning, press the **STOP/RST** will stop the autotuning.

Notice: Only keypad can control the autotuning. P0.08 will restore to 0 automatically when the autotuning is finished or cancelled.

2: Static autotuning:

- If it is difficult to disconnect the load, static autotuning is recommended.
- The operation process is the same as rotation autotuning except step c.

Notice: The mutual inductance and current without load will not be detected by static autotuning, if needed user should input suitable value according to experience.

Function Code	Name	Description	Setting Range	Factory Setting
P0.09	Restore parameters	0: No action 1: Restore factory setting 2: Clear fault records	0~2	0

0: No action

1: Inverter restores all parameters to factory setting except P2 group.

2: Inverter clear all fault records.

Function Code	Name	Description	Setting Range	Factory Setting
P0.10	Reserve	Reserve	0~65535	0
P0.11	Reserve	Reserve	0~65535	0

6.2 P1 Group--Speed curve

Function Code	Name	Setting Range	Factory Setting
P1.00	Multi-step speed 0	0.000~P0.02	0.000m/s
P1.01	Multi-step speed 1	0.000~P0.02	0.000m/s
P1.02	Multi-step speed 2	0.000~P0.02	0.000m/s
P1.03	Multi-step speed 3	0.000~P0.02	0.000m/s
P1.04	Multi-step speed 4	0.000~P0.02	0.000m/s
P1.05	Multi-step speed 5	0.000~P0.02	0.000m/s
P1.06	Multi-step speed 6	0.000~P0.02	0.000m/s
P1.07	Multi-step speed 7	0.000~P0.02	0.000m/s

Multi-step speed is defined by P1.00~P1.07. The 8-step speed will be come ture by combination of 3 multi-step speed terminals. The detailed description is as follow:

Multi-step speed terminal 3	Multi-step speed terminal 2	Multi-step speed terminal 1	Speed Setting	Function Code
OFF	OFF	OFF	Multi-step speed 0	P1.00
OFF	OFF	ON	Multi-step speed 1	P1.01
OFF	ON	OFF	Multi-step speed 2	P1.02
OFF	ON	ON	Multi-step speed 3	P1.03
ON	OFF	OFF	Multi-step speed 4	P1.04
ON	OFF	ON	Multi-step speed 5	P1.05
ON	ON	OFF	Multi-step speed 6	P1.06
ON	ON	ON	Multi-step speed 7	P1.07

Function Code	Name	Setting Range	Factory Setting
P1.08	Start quadric acceleration	0.001~10.000	0.350m/s ³
P1.09	Start acceleration	0.001~10.000	0.700m/s ²
P1.10	Speed-down quadric deceleration	0.001~10.000	0.350m/s ³
P1.11	Deceleration	0.001~10.000	0.700m/s ²
P1.12	Stop quadric deceleration	0.001~10.000	0.350m/s ³
P1.13	Stop deceleration	0.001~10.000	0.700m/s ²
P1.14	Start speed	0.000~0.250	0.000m/s
P1.15	Start holding time	0.0~5.0s	0.0s

The sharp of S-curve was decided by P1.08~P1.13, the quality of S-curve can direct effect the comfort of elevator's start and stop. The parameters of S-curve were comprised of Start quadric acceleration(P1.08), Start acceleration(P1.09), Speed-down quadric deceleration(P1.10), Deceleration(P1.11), Stop quadric deceleration(P1.12), Stop deceleration(P1.13), Start speed(P1.14) and Start holding time(P1.15). The correspondence of these parameters and S-curve is as follow:

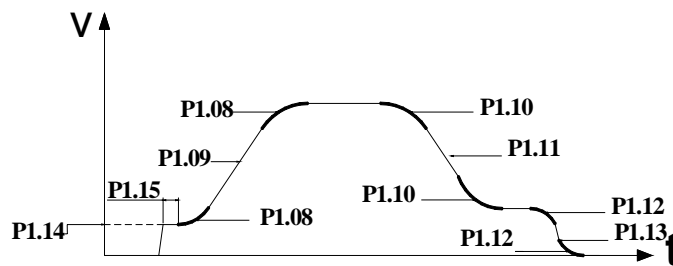

Figure 6.2 S - curve running diagram.

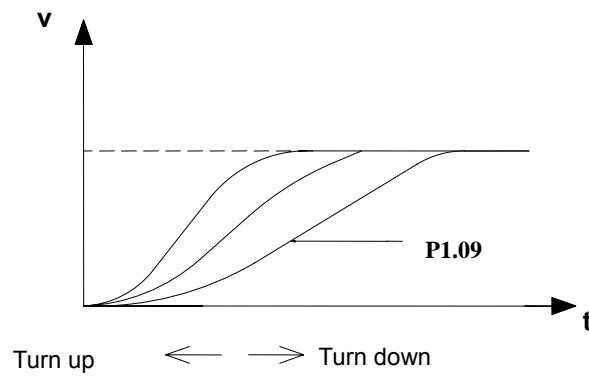

Figure 6.3 S - curve setting sketch map description.

The above diagram is the sketch map of setting S-curve of accelerated portion, the S-curve steepen as the parameter was increase, and the S-curve slacken as the parameter was decrease. The principle of setting S-curve in on decelerated, stop portion and accelerated portion are the same.

P1.14 is the initial speed at the inverter starting. At the time of inverter running, if the setting speed is less than start speed, the output frequency is 0. Only when the setting speed is greater than or equal to start speed, the inverter will start running from 0, and according to S-curve. If you set a right value, you can get over breakout friction at starting, and decrease shock.

P1.15 is the time of running at starting speed in the process of starting.

NOTICE: P1.08, P1.10 and P1.12 are main parameters of S-curve, and these parameter can influence the passengers' comfort when accelerating, decelerating and stopping respectively, so you should carefully set the parameters.

Function Code	Name	Setting Range	Factory Setting
P1.16	Overhaul running speed	0.000~P0.02	0.300m/s
P1.17	Overhaul running acceleration	0.001~10.000	1.000m/s ²
P1.18	Overhaul running deceleration	0.001~10.000	1.000m/s ²

Setting overhaul running speed, acceleration and deceleration. The overhaul curve is as follow:

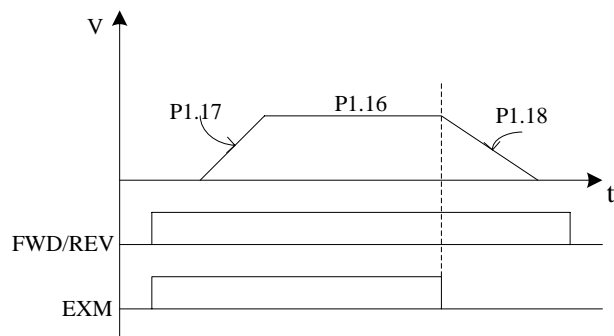

Figure 6.4 Overhaul ruing curve.

For detailed curve and sequence chart, you can refer to chapter 8.2.2.

Notice: The priority of speed selection is that: force decelerate > emergeny run > overhaul run > multi-step speed run > keypad setting, analog quantity setting or communication setting.

Function Code	Name	Setting Range	Factory Setting
P1.19	Motor autotuning acceleration	0.001~10.000	0.600 m/s ²
P1.20	Motor autotuning deceleration	0.001~10.000	0.600m/s ²

Setting acceleration and deceleration of motor's parameter autotuning.

Function Code	Name	Setting Range	Factory Setting
P1.21	Emergence running acceleration	0.000~P0.02	0.300m/s
P1.22	Emergence running deceleration	0.001~10.000	1.000m/s ²

Setting speed, acceleration and deceleration of emergency running.

1. The description of emergency running is as follow: at the time of power-off, the control system let the power of accumulator switch on (+) and (-) terminals with bypass switch. Inverter receives the command of emergency running speed and running direction from controller, and elevator will stop to the closer flat bed

automatically.

2. The wiring of emergency running:

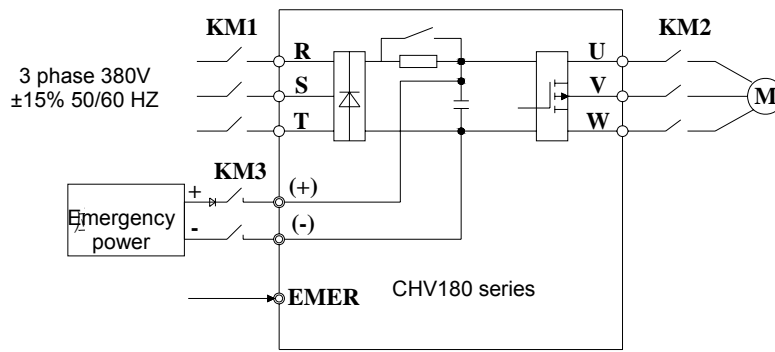

Figure 6.5 The wiring of emergency running.

3. The curve and sequence chart of emergency running:

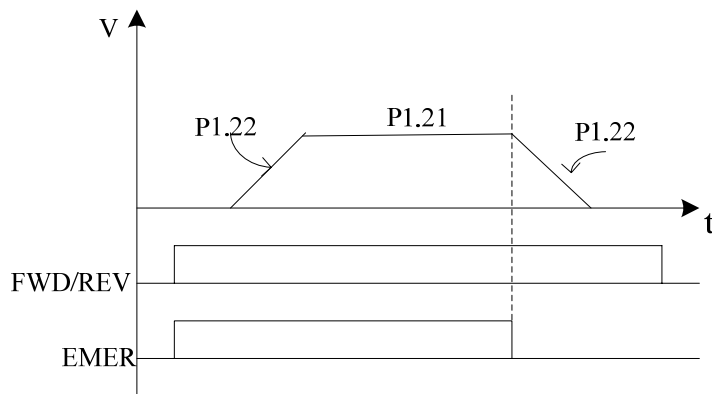

Figure 6.6 The emergency running curve.

For detailed emergency running, you can refer to chapter 8.2.3.

Notice: if you use the emergency running, you need screen the protecting function of inverter, and P9.00=0

Detailed Function Description

Function Code	Name	Setting Range	Factory Setting
P1.23	Forcing slow-down deceleration 1	P1.25~10.000	1.000m/s ²
P1.24	Forcing slow-down speed 1 check	0.0~P1.26	20.0%
P1.25	Forcing slow-down deceleration 2	P1.27~P1.23	0.900m/s ²
P1.26	Forcing slow-down speed 2 check	P1.24~P1.28	40.0%
P1.27	Forcing slow-down deceleration 3	0.001~P1.25	0.700m/s ²
P1.28	Forcing slow-down speed 3 check	P1.26~100.0%	80.0%

The above parameters will be effect, after it selects forcing slow-down switch input, the effect of forcing slow-down is that preventing elevator break top or bottom in the process of up or down running. During the elevator running with low speed, there is only one group of forcing slow-down switch. But during the elevator running with high speed, there are two to three groups of forcing slow-down switch. The installation sketch map is like figure 6.7:

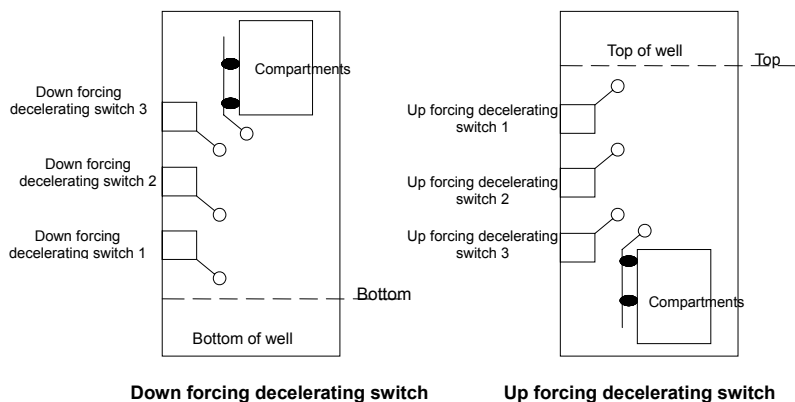

Figure 6.7 Installation sketch of forcing slow-down switch.

For example, during the elevator up running, elevator meet the forcing slow-down switch 3, when the elevator is close to top, up forcing slow-down switch 3 will act, if the checked running speed is more than P1.28XP0.02 at this time, elevator will decelerate with P1.27,

down to P1.28XP0.02, and elevator decelerate with S-curve. The detailed curve is as follow:

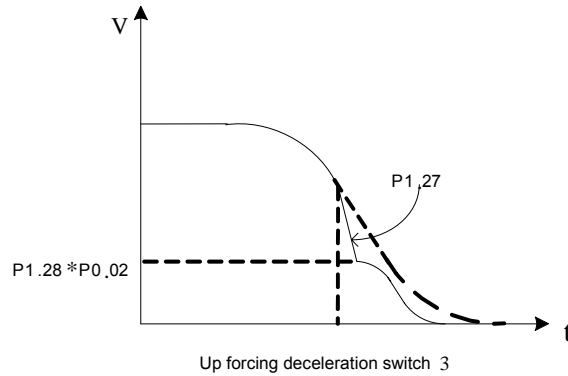

Figure 6.8 Forcing decelerating running chart.

Forcing slow-down running conditions:

1. Need feedback terminals of forcing slow-down switch acting.
2. During up running, meeting up forcing switch, or down running, meeting down forcing switch.
3. Current running speed is more than the corresponding check speed of forcing slow-down switch, if it is less than that, the inverter will run with atempo.

After forcing decelerating action, the speed will be reduced to P1.24, P1.26, P1.28 with P1.23, P1.25, P1.27.

Notice: The priority of forcing slow-down is the highest, the priority is like this: forcing slow-down 1 > forcing slow-down 2 > forcing slow-down 3.

Function Code	Name	Setting Range	Factory Setting
P1.29	Stop mode selection	0~1	1

0: Deceleration to stop

When the stop command takes effect, the inverter decreases the output frequency according to stop deceleration and stop quadric deceleration till stop.

1: Coast to stop

When the stop command takes effect, the inverter blocks the output immediately. The motor coasts to stop by its mechanical inertia.

Detailed Function Description

Function Code	Name	Setting Range	Factory Setting
P1.30	Reserve function	0~65535	0
P1.31	Reserve function	0~65535	0

6.3 P2 Group--Motor Parameters

Function Code	Name	Description	Setting Range	Factory Setting
P2.00	Inverter Model	0: asynchronous motor 1: synchronous motor	0~1	0

0: asynchronous motor

1: synchronous motor

Notice: Select right model of motor before performing parameters autotuning.

Function Code	Name	Setting Range	Factory Setting
P2.01	Traction motor wheel diameter	100~2000	500mm
P2.02	Speed-down rate	1.00~100.00	30.00
P2.03	Tow hanging rate	1~8	1

P2.01、P2.02、P2.03 are parameters of the elevator traction motor, no other than select these parameters correctly, the inverter showing running-speed can be right parallelism with elevator's factual speed. Frondose connection refers to P0.02.

Function Code	Name	Description	Setting Range	Factory Setting
P2.04	Motor rated power	0.4~900.0kW	0.4~900.0	Depend on model
P2.05	Motor rated frequency	0.01Hz~P0.04	0.01~P0.04	50.00Hz
P2.06	Motor rated speed	0~36000rpm	0~36000	1460rpm
P2.07	Motor rated voltage	0~460V	0~460	380V
P2.08	Motor rated current	0.1~1000.0A	0.1~1000.0	Depend on model

Notice:

- In order to achieve superior performance, please set these parameters according to motor nameplate, then perform autotuning.
- The power rating of inverter should match the motor. If the bias is too big, the control performances of inverter will be deteriorated distinctly.

- **Reset P2.05 can initialize P2.06~P2.10 automatically.**

Function Code	Name	Setting Range	Factory Setting
P2.09	Motor rating power factor	0.05~1.00	0.86

When the inverter cannot perform autotuning, may optimize motor control performance by set the motor rating power factor.

Function Code	Name	Description	Setting Range	Factory Setting
P2.10	Motor stator resistance	0.001~65.535Ω	0.001~65.535	Depend on model
P2.11	Motor rotor resistance	0.001~65.535Ω	0.001~65.535	Depend on model
P2.12	Motor leakage inductance	0.1~6553.5mH	0.1~6553.5	Depend on model
P2.13	Motor mutual inductance	0.1~6553.5mH	0.1~6553.5	Depend on model
P2.14	Current without load	0.01~655.35A	0.01~655.35	Depend on model

After autotuning, the value of P2.10~P2.14 will be automatically updated.

Notice: Do not change these parameters; otherwise it may deteriorate the control performance of inverter.

Function Code	Name	Setting Range	Factory Setting
P2.15	Reserve function	0~65536	0
P2.16	Reserve function	0~65536	0

6.4 P3 Group--Vector Control

Function Code	Name	Description	Setting Range	Factory Setting
P3.00	ASR low speed proportion plus	0~100	0~100	20
P3.01	ASR low speed integral time	0.01~10.00s	0.01~10.00s	0.50s
P3.02	Speed inspect low speed filter time	0.000~1.000s	0.000~1.000s	0.000s
P3.03	Switch low frequency	0.00Hz~P3.05	0.00~P3.05	5.00Hz
P3.04	ASR high speed proportion plus	0.01~10.00s	0.01~10.00s	1.00s
P3.05	ASR high speed integral time	P3.02~P0.07	P3.02~P0.07	10.00Hz
P3.06	Speed inspect high speed filter time	0.000~1.000s	0.000~1.000s	0.000s

Detailed Function Description

P3.07	Switch high frequency	P3.03~P0.04	P3.03~P0.04	10.00Hz
-------	-----------------------	-------------	-------------	---------

P3.00~P3.05 are only valid for vector control and torque control and invalid for V/F control. Through P3.00~P3.05, user can set the proportional gain K_p and integral time K_i of speed regulator (ASR), so as to change the speed response characteristic.

P3.00 and P3.01 only take effect when output frequency is less than P3.02. P3.03 and P3.04 only take effect when output frequency is greater than P3.05. When output frequency is between P3.02 and P3.05, K_p and K_i are proportional to the bias between P3.02 and P3.05. For details, please refer to following figure.

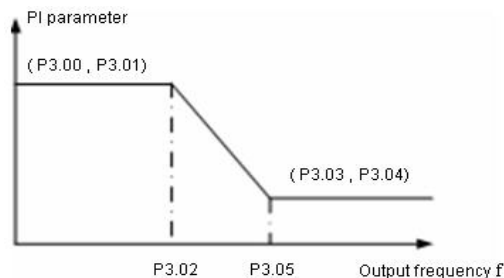

Figure 6.9 PI parameter diagram.

The system's dynamic response can be faster if the proportion gain K_p is increased; However, if K_p is too large, the system tends to oscillate.

The system dynamic response can be faster if the integral time K_i is decreased; However, if K_i is too small, the system becomes overshoot and tends to oscillate.

P3.00 and P3.01 are corresponding to K_p and K_i at low frequency, while P3.03 and P3.04 are corresponding to K_p and K_i at high frequency. Please adjust these parameters according to actual situation. The adjustment procedure is as follow:

1. Increase the proportional gain (K_p) as far as possible without creating oscillation.
2. Reduce the integral time (K_i) as far as possible without creating oscillation.

For more details about fine adjustment, please refer to description of P9 group.

Function Code	Name	Description	Setting Range	Factory Setting
P3.08	ACR proportional gain P	0~65535	0~65535	500
P3.09	ACR integral gain I	0~65535	0~65535	500

The bigger the proportional gain P, the faster the response, but oscillation may easily occur. If only proportional gain P is applied in regulation, the bias cannot be eliminated.

In order to eliminate the bias, apply the integral gain I to achieve PI regulator.

Function Code	Name	Description	Setting Range	Factory Setting
P3.10	Slip compensation rate of drive side	50.0~200.0%	50~200	100%
P3.11	Slip compensation rate of trig side	50.0~200.0%	50~200	100%

The parameter is used to adjust the slip frequency of vector control and improve the precision of speed control. Properly adjusting this parameter can effectively restrain the static speed bias.

CHV180 series inverter abet to set electromotion state and regenerate brake state separately, P3.10 is the same with electromotion state, P3.11 is the same with regenerate feedback state.

Function Code	Name	Description	Setting Range	Factory Setting
P3.12	Torque upper limit	0.0~200.0%	0.0~200.0	150.0%

100.0% corresponds inverter's rating current.

Function Code	Name	Setting Range	Factory Setting
P3.13	Reserve function	0~65536	0
P3.14	Reserve function	0~65536	0

6.5 P4 Group -- Encoder parameter

Function Code	Name	Setting Range	Factory Setting
P4.00	Encoder type selection	0~2	0

When selecting the type of encoder, asynchronous motor and synchronous motor need different PG card, please refer to chapter 7.3 and 7.4 for wiring of encoder.

0: Increment encoder

1: SIN/COS encoder

2: UVM encoder

Function Code	Name	Setting Range	Factory Setting
P4.01	PG parameter	1~65536	1000
P4.02	PG direction selection	0~1	0

Setting the number of encoder pulse per cycle.

Detailed Function Description

Notice: When P0.00 is set to be 1, P3.10 must be set correctly according to the encoder parameter, otherwise the motor will run abnormally. If the motor still run abnormally when P3.10 has been set correctly, please change the PG direction (P3.11).

Function Code	Name	Description	Setting Range	Factory Setting
P4.03	Pole initial position	0.00~360.00	0.00~360.00	0.00
P4.07	Pole position amplitude plus	0.50~1.50	0.50~1.50	1.00
P4.08	C phase pole position offset	0~999	0~999	385
P4.09	D phase pole position offset	0~999	0~999	385

After autotuning, the above parameters will be updated, and please don't adjust these parameters facilely bu user.

Function Code	Name	Description	Setting Range	Factory Setting
P4.04	Thread break detection time of encoder low speed	0.0~100.0s	0.0~100.0s	1.0
P4.05	Thread break detection time of encoder high speed	0.0~100.0s	0.0~100.0s	1.0
P4.06	Reverse detection time of encoder	0.0~100.0s	0.0~100.0s	1.0

Thread break detection time of encoder is defined by P4.04 and P4.05, when the time of encoder thread break is more than setting time of encoder thread break, the inverter will show fault of encoder thread break (PCE), P4.04 corresponds to low speed, and P4.05 corresponds to high speed.

Reverse detection time of encoder is defined by P4.06, when the time of reverse time of encoder is more than corresponding thread break deteaction time, the system will show fault of encoder reverse encoder (PCDE).

Notice: Setting the above parameters will influence delicacy of encoder fault protection, please adjust these parameters carefully.

Function Code	Name	Setting Range	Factory Setting
P4.10	Reserve function	0~65536	0
P4.11	Reserve function	0~65536	0

6.6 P5 Group--Input Terminals

Function	Name	Description	Setting Range	Factory
----------	------	-------------	---------------	---------

Code				Setting
P5.00	Terminal input mode selection	0~0x3FF	0~0x3FF	0

ON-OFF signal input terminals choose constant on or off. As corresponding bit is 1, the input is off. This parameter is 16 conversion setting. ON-OFF signal corresponding bit is as follows:

BIT9	BIT8	BIT7	BIT6	BIT5
S10	S9	S8	S7	S6
BIT4	BIT3	BIT2	BIT1	BIT0
S5	S4	S3	S2	S1

Function Code	Name	Description	Setting Range	Factory Setting
P5.01	Communication virtual terminal function selection	0: Invalid 1: Valid	0~1	0

0: ON-OFF signal is input through external input terminals.

1: ON-OFF signal is set through serial communication by host device.

Function Code	Name	Description	Setting Range	Factory Setting
P5.02	S1 Terminal function	Programmable multifunction terminal	0~55	1
P5.03	S2 Terminal function	Programmable multifunction terminal	0~55	2
P5.04	S3 Terminal function	Programmable multifunction terminal	0~40	8
P5.05	S4 Terminal function	Programmable multifunction terminal	0~40	9
P5.06	S5 Terminal function	Programmable multifunction terminal	0~40	3
P5.07	S6 Terminal function	Programmable multifunction terminal	0~40	0
P5.08	S7 Terminal function	Programmable multifunction terminal	0~40	0
P5.09	S8 Terminal function	Programmable multifunction terminal	0~40	0

Detailed Function Description

Function Code	Name	Description	Setting Range	Factory Setting
P5.10	S9 Terminal function	Programmable multifunction terminal	0~40	0
P5.11	S10Terminal function	Programmable multifunction terminal	0~40	0

This parameter is used for setting digital multifunction terminals' corresponding function.

0: No function

1: Up running (FWD)

2: Down running (REV)

When the running command is terminal control, the elevator's up and down commands are controlled by the terminal.

3: Examine running (EXM)

This terminal is used for selecting elevator come into EXM state, this signal works with up and down running signal, and can control elevator carry out EXM work.

4: Emergency running (EMER)

This terminal is used for selecting elevator come into EMER state, this signal works with up and down running signal, and can control elevator carry out EXM work.

5: Coast to stop (FSTP)

Inverter blockades output, motor's stopping process is not controlled by inverter. This mode has the same meaning as described in P1.29.

6: Fault reset

Exterior fault reset function, is used for far distance failure reset, and has the same function as STOP/RST key on keyboard.

7: External fault input (EF)

After this signal is available, inverter reports exterior fault (EF) and stop.

8~10: Multi-speed terminals 1~3

The combination of the three terminals can achieve the speed set in 8 steps.

Notice : Terminal 1 is for low-speed, terminal 3 is for high-speed.

Multi-step speed 3	Multi- step speed 2	Multi- step speed 1
BIT2	BIT1	BIT0

11~13: Uplink forcing deceleration 1~3

Uplink forcing signal, is use for preventing the elevator clash to the top. Please refer to P1.23 ~ P1.28 for the description of specific function.

14 ~ 16: Downlink forcing deceleration 1~3

Downlink forcing signal, is use for preventing the elevator clash to the bottom. Please refer to P1.23 ~ P1.28 for the description of specific function.

17: Contactor feedback signal (TB)

P8.04 selects contactor control to be available, if contactor feedback signal is wrong, inverter will report contactor feedback fault (TbE).

18: Brake feedback signal (FB)

P8.04 selects brake control to be available, if brake feedback signal is wrong, inverter will report brake feedback fault (TbE).

19: Inverter enable (ENA)

When a multi-functional terminal is set to be inverter enabled, the inverter can run, only after the ENA signal is available, otherwise the inverter does not respond to running command. If not choose this function, inverter default can be effective.

20~40: Reservation

Function Code	Name	Description	Setting Range	Factory Setting
P5.12	ON-OFF filter times	1~10	1~10	5

This parameter is used to set filter strength of terminals (S1~S8). When interference is heavy, user should increase this value to prevent malfunction.

Function Code	Name	Description	Setting Range	Factory Setting
P5.13	AI1 lower limit	0.00V~10.00V	0.00~10.00	0.00V
P5.14	AI1 lower limit corresponding setting	-100.0%~100.0%	-100.0~100.0	0.0%
P5.15	AI1 upper limit	0.00V~10.00V	0.00~10.00	10.00V
P5.16	AI1 upper limit corresponding setting	-100.0%~100.0%	-100.0~100.0	100.0%
P5.17	AI1 filter time constant	0.00s~10.00s	0.00~10.00	0.10s

These parameters determine the relationship between analog input voltage and the corresponding setting value. When the analog input voltage exceeds the range between lower limit and upper limit, it will be regarded as the upper limit or lower limit.

The analog input AI1 can only provide voltage input, and the range is 0V~10V.

For different applications, the corresponding value of 100.0% analog setting is different.

For details, please refer to description of each application.

Notice: AI1 lower limit must be less or equal to AI1 upper limit.

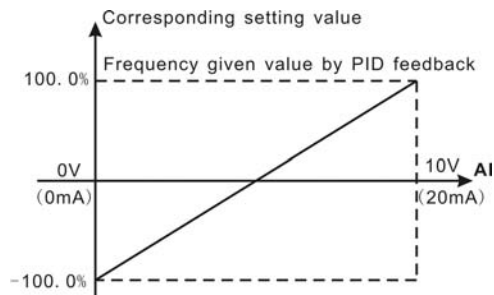

Figure 6.10 Relationship between AI and corresponding setting.

Function Code	Name	Description	Setting Range	Factory Setting
P5.20	AI2 lower limit	0.00V~10.00V	0.00~10.00	0.00V
P5.21	AI2 lower limit corresponding setting	-100.0%~100.0%	-100.0~100.0	0.0%
P5.22	AI2 upper limit	0.00V~10.00V	0.00~10.00	5.00V
P5.23	AI2 upper limit corresponding setting	-100.0%~100.0%	-100.0~100.0	100.0%
P5.24	AI2 filter time constant	0.00s~10.00s	0.00~10.00	0.10s

Please refer to description of AI1.

Notice: When AI2 is set as 0~20mA current input, the corresponding voltage range is 0~5V.

6.7 P6 Group -- Output Terminals

Function Code	Name	Description	Setting range	Factory Setting
P6.00	HDO selection	0: High-speed pulse output 1: Open collector output	0~1	0

0: High-speed pulse output: The maximum pulse frequency is 50.0 kHz. Please refer to description of P6.09.

1: ON-OFF output: Please refer to description of P6.03.

Notice: The output of HDO terminal is multi-function ON-OFF output.

Function Code	Name	Description	Setting Range	Factory Setting
P6.01	Y1 output selection	Open-collector	0~31	1

Detailed Function Description

		output		
P6.02	Y2 output selection	Open-collector output	0~31	0
P6.03	HDO ON-OFF output selection	Open-collector output	0~31	0
P6.04	Relay 1 output selection	Relay output	0~31	3
P6.05	Relay 2 output selection	Relay output	0~31	0
P6.06	Relay 3 output selection	Relay output	0~31	0

OC/Relay output functions are indicated in the following table:

Setting Value	Function	Description
0	No output	Output terminal has no function.
1	Elevator running	ON: During run.
2	Up running	ON: During up run.
3	Down running	ON: During down run.
4	Fault output	ON: Inverter is in fault status.
5	Zero speed running	ON: The running frequency of inverter is zero.
6	Ready	ON: Inverter is ready (no fault, power is ON).
7	Holding-brake control	ON: take off the brake OFF: hold the brake
8	Contactors control	ON: close the contactor. OFF: open the contactor.
9	Frequency reached	Please refer to description of P6.24.
10	FDT reached	Please refer to description of P6.22, P6.23.
11~20	Reserved	Reserved

Function Code	Name	Description	Setting Range	Factory Setting
---------------	------	-------------	---------------	-----------------

Detailed Function Description

P6.07	AO1 function selection	Multifunctional analog output	0~14	0
P6.08	AO2 function selection	Multifunctional analog output	0~14	0
P6.09	HDO function selection	Multifunctional high-speed pulse output	0~14	0

AO/HDO output functions are indicated in the following table:

Setting Value	Function	Range
0	Running speed	0~maximum speed
1	Reference speed	0~ maximum speed
2	Motor running speed	0~2* rated synchronous speed of motor
3	Output current	0~2* inverter rated current
4	Output voltage	0~2* inverter rated voltage
5	Output power	0~2* rated power
6	Output torque	0~2*rated torque
7	AI1 voltage	0~10V
8	AI2 voltage/current	0~10V/0~20mA
9~14	Reserved	Reserved

Function Code	Name	Description	Setting Range	Factory Setting
P6.10	AO1 lower limit	0.0%~P6.12	0.0~ P6.12	0.0%
P6.11	AO1 lower limit corresponding output	0.00V ~10.00V	0.00~10.00	0.00V
P6.12	AO1 upper limit	0.0%~100.0%	P6.10~100.0	100.0%
P6.13	AO1 upper limit corresponding output	0.00V ~10.00V	0.00~10.00	10.00V
P6.14	AO2 lower limit	0.0%~ P6.16	0.0~ P6.16	0.0%
P6.15	AO2 lower limit corresponding output	0.00V ~10.00V	0.00~10.00	0.00V
P6.16	AO2 upper limit	0.0%~100.0%	P6.14~100.0	100.0%

P6.17	AO2 upper limit corresponding output	0.00V ~10.00V	0.00~10.00	10.00V
-------	---	---------------	------------	--------

These parameters determine the relationship between analog output voltage/current and the corresponding output value. When the analog output value exceeds the range between lower limit and upper limit, it will output the upper limit or lower limit.

When AO is current output, 1mA is corresponding to 0.5V.

For different applications, the corresponding value of 100.0% analog output is different.

For details, please refer to description of each application.

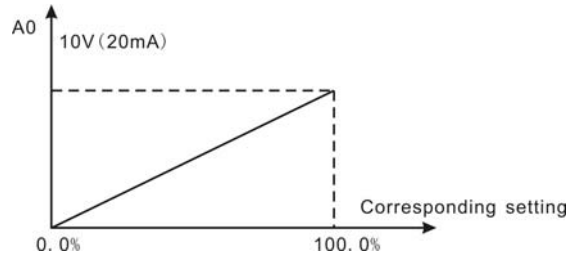

Figure 6.11 Relationship between AO and corresponding setting.

Function Code	Name	Description	Setting Range	Factory Setting
P6.18	HDO lower limit	0.0%~ P6.20	0.0~ P6.20	0.0%
P6.19	HDO lower limit corresponding output	0.0 ~ 50.0kHz	0.0~50.0	0.0kHz
P6.20	HDO upper limit	0.0%~100.0%	P6.18~100.0	100.0%
P6.21	HDO upper limit corresponding output	0.0 ~ 50.0kHz	0.0~50.0	50.0kHz

The description of P6.18~P6.21 is similar to AO.

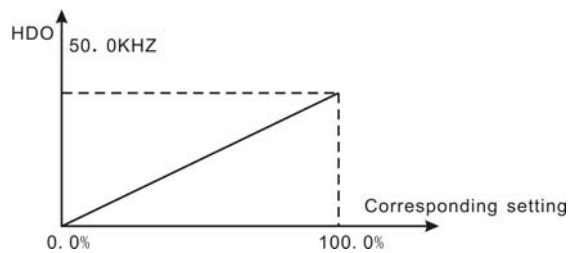

Figure 6.12 Relationship between HDO and corresponding setting.

Detailed Function Description

Function Code	Name	Setting Range
P6.22	FDT level	0.00~P0.07 【50.00Hz】
P6.23	FDT lag	0.0~100.0 【5.0%】

When the output frequency reaches a certain preset frequency (FDT level), output terminal will output an ON-OFF signal until output frequency drops below a certain frequency of FDT level (FDT level - FDT lag), as shown in following figure.

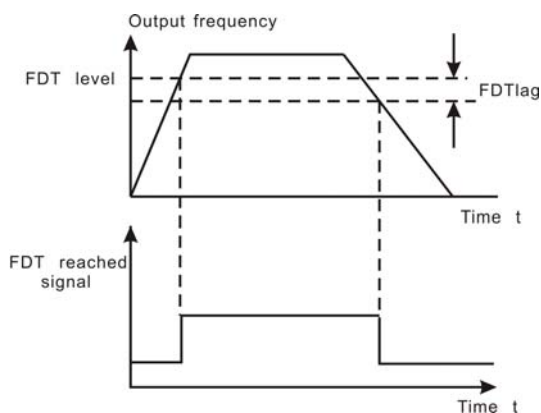

Figure 6.13 FDT Level diagram.

Function Code	Name	Setting Range
P6.24	Frequency reach detecting range	0.00~100.0% 【0.0%】

When output frequency is within the detecting range of reference frequency, an ON-OFF signal will be output.

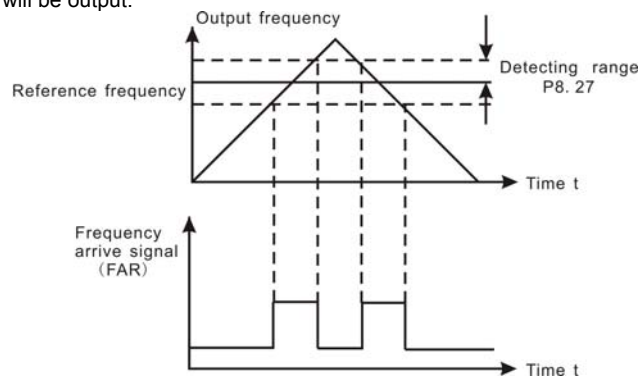

Figure 6.14 Frequency arriving detection diagram.

Function Code	Name	Setting Range
P6.25	Reserved	0~65535 【0】
P6.26	Reserved	0~65535 【0】

6.8 P7 Group --Display Interface

Function Code	Name	Description	Setting Range	Factory Setting
P7.00	User password	0~65535	0~65535	0

The password protection function will be valid when set to be any nonzero data. When P7.00 is set to be 00000, user's password set before will be cleared and the password protection function will be disabled.

After the password has been set and becomes valid, the user can not access menu if the user's password is not correct. Only when a correct user's password is input, the user can see and modify the parameters. Please keep user's password in mind.

Function Code	Name	Description	Setting Range	Factory Setting
P7.01	LCD language selection	0: Chinese 1: English	0~1	0
P7.02	Parameter copy	0: Invalid 1: Upload parameters to LCD 2: Download parameters from LCD	0~2	0

P7.02 will take effect when LCD keypad is used.

1: All value of parameters will be uploaded from inverter to LCD.

2: All value of parameters will be downloaded from LCD to inverter.

Notice: When upload or download operation completes, P7.02 will be set to 0 automatically.

Function Code	Name	Description	Setting Range	Factory Setting
P7.03	<u>QUICK/JOG</u> function selection	0: Quick debugging mode 1: FDW/REV switching	0~1	0

QUICK/JOG is a multifunctional key, whose function can be defined by the value of P7.03.

0: Quick debugging mode: Please refer to description of Chapter 5.

1: FWD/REV switching: Press QUICK/JOG, the running direction of inverter will reverse.

Detailed Function Description

It is only valid if P0.01 is set to be 0.

Function Code	Name	Description	Setting Range	Factory Setting
P7.04	STOP/RST function selection	0: Valid when keypad control (P0.01=0) 1: Valid when keypad or terminal control (P0.01=0 or 1) 2: Valid when keypad or communication control (P0.01=0 or 2) 3: Always valid	0~3	0

Notice:

- The value of P7.04 only determines the STOP function of **STOP/RST**.
- The RESET function of **STOP/RST** is always valid.

Function Code	Name	Description	Setting Range	Factory Setting
P7.05	Keypad display selection	0: Preferential to external keypad 1: Both display, only external key valid. 2: Both display, only local key valid. 3: Both display and key valid.	0~3	0

0: When external keypad exists, local keypad will be invalid.

1: Local and external keypad display simultaneously, only the key of external keypad is valid.

2: Local and external keypad display simultaneously, only the key of local keypad is valid.

3: Local and external keypad display simultaneously, both keys of local and external keypad are valid. **This function should be used cautiously, otherwise it may cause malfunction.**

Notice:

- When P7.05 is set to be 1, local keypad is valid if external keypad is not connected.
- When LCD keypad is connected, P7.05 must be set to be 0.

Detailed Function Description

Function Code	Name	Description	Setting Range	Factory Setting
P7.06	Running status display selection	0~0xFFFF	0~0xFFFF	0x00FF

P7.06 defines the parameters that can be displayed by LED in running status. If Bit is 0, the parameter will not be displayed; If Bit is 1, the parameter will be displayed. Press  **[SHIFT]** to scroll through these parameters in right order. Press **[DATA/ENT]** + **[QUICK/JOG]** to scroll through these parameters in left order.

The display content corresponding to each bit of P7.06 is described in the following:

[BIT7]	[BIT6]	[BIT5]	[BIT4]	[BIT3]	[BIT2]	[BIT1]	[BIT0]
A12	A11	Output terminal status	Input terminal status	Output torque	Output power	Rotation speed	Running frequency
[BIT15]	[BIT14]	[BIT13]	[BIT12]	[BIT11]	[BIT10]	[BIT9]	[BIT8]
Reserve	Reserve	Reserve	Reserve	Reserve	Reserve	Pole position	Torque compensation

Notice: I/O terminal status is displayed in decimal. For details, please refer to description of P7.19 and P7.20.

Function Code	Name	Description	Setting Range	Factory Setting
P7.07	Stop status display selection	1~0xFFFF	1~0xFFFF	0x00FF

P7.07 determines the display parameters in stop status. The setting method is similar with P7.06.

The display content corresponding to each bit of P7.07 is described in the following table:

[BIT7]	[BIT6]	[BIT5]	[BIT4]	[BIT3]	[BIT2]	[BIT1]	[BIT0]
A12	A11	Motor poles	Output terminal status	Input terminal status	DC bus voltage	Reference frequency	Reference speed
[BIT15]	[BIT14]	[BIT13]	[BIT12]	[BIT11]	[BIT10]	[BIT9]	[BIT8]
Reserve	Reserve	Reserve	Reserve	Reserve	Reserve	Reserve	Pole position

Detailed Function Description

Function Code	Name	Description	Setting Range	Factory Setting
P7.08	Rectifier module temperature	0~100.0℃		
P7.09	IGBT module temperature	0~100.0℃		
P7.10	MCU software version			
P7.11	DSP software version			
P7.12	Accumulated running time	0~65535h		

Rectifier module temperature: Indicates the temperature of rectifier module. Overheat protection point of different inverter may be different.

IGBT module temperature: Indicates the temperature of IGBT module. Overheat protection point of different inverter may be different.

MCU Software version: Indicates current software version of MCU.

DSP Software version: Indicates current software version of DSP

Accumulated running time: Displays accumulated running time of inverter.

Notice: Above parameters are read only.

Function Code	Name	Description	Setting Range	Factory Setting
P7.13	Third latest fault type	0~30	0~30	
P7.14	Second latest fault type	0~30	0~30	
P7.15	Latest fault type	0~30	0~30	

These parameters record three recent fault types. For details, please refer to description of chapter 7.

Function Code	Name	Description	Setting Range	Factory Setting
P7.16	Output frequency at current fault	Output frequency at current fault.		
P7.17	Output current at current fault	Output current at current fault.		
P7.18	DC bus voltage at current fault	DC bus voltage at current fault.		

P7.19	Input terminal status at current fault	<p>This value records ON-OFF input terminal status at current fault. The meaning of each bit is as below:</p> <table border="1"> <tr> <td>9</td><td>8</td><td>7</td><td>6</td><td>5</td><td>4</td><td>3</td><td>2</td><td>1</td><td>0</td> </tr> <tr> <td>S8</td><td>S7</td><td>S6</td><td>HDI2</td><td>HDI1</td><td>S5</td><td>S4</td><td>S3</td><td>S2</td><td>S1</td> </tr> </table> <p>1 indicates corresponding input terminal is ON, while 0 indicates OFF. Notice: This value is displayed as decimal.</p>	9	8	7	6	5	4	3	2	1	0	S8	S7	S6	HDI2	HDI1	S5	S4	S3	S2	S1		
9	8	7	6	5	4	3	2	1	0															
S8	S7	S6	HDI2	HDI1	S5	S4	S3	S2	S1															
P7.20	Output terminal status at current fault	<p>This value records output terminal status at current fault. The meaning of each bit is as below:</p> <table border="1"> <tr> <td>BIT5</td><td>BIT4</td><td>BIT3</td><td>BIT2</td><td>BIT1</td><td>BIT0</td> </tr> <tr> <td>RO3</td><td>RO2</td><td>RO1</td><td>HDO</td><td>Y2</td><td>Y1</td> </tr> </table> <p>1 indicates corresponding output terminal is ON, while 0 indicates OFF. Notice: This value is displayed as decimal.</p>	BIT5	BIT4	BIT3	BIT2	BIT1	BIT0	RO3	RO2	RO1	HDO	Y2	Y1										
BIT5	BIT4	BIT3	BIT2	BIT1	BIT0																			
RO3	RO2	RO1	HDO	Y2	Y1																			

Function Code	Name	Setting Range	Factory Setting
P7.21	Reserve function	0~65536	0
P7.22	Reserve function	0~65536	0

6.9 P8 Group --Enhanced Function

Function Code	Name	Setting Range	Factory Setting
P8.00	Analog weigh signal input selection	0~2	0

0: No function

1: AI1

2: AI2

This parameter can improve comfort of elevator.

NOTICE: This analog signal and speed command selection (P0.03) can't use the same one analog input.

Function Code	Name	Description	Setting Range	Factory Setting
P8.01	Preparation torque offset	0.0~100.0%	0.0~100.0%	30.0%
P8.02	Gain of drive side	0.000~7.000	0.000~7.000	1.000
P8.03	Gain of brake side	0.000~7.000	0.000~7.000	1.000

Detailed Function Description

When elevator running, the start comfort is be improved by preparation torque compensating difference value of car and counterpoise. Only when P8.00 isn't set to 0, preparation torque compensation will be available. The detailed way and size are as follow:

Dirction running	Compare	Beforehand compensation value
Up running	Car > counterpoise	$P8.02 * (car - P8.01)$
	Car < counterpoise	$P8.03 * (car - P8.01)$
Down running	Car > counterpoise	$P8.03 * (car - P8.01)$
	Car < counterpoise	$P8.02 * (car - P8.01)$

$P8.01 = (\text{comterpoise weight} - \text{car weight}) / \text{rated load weight of elevator.}$

Function Code	Name	Description	Setting Range	Factory Setting
P8.04	Holding brake, contactor control selection	0~3	0~3	0

0: Holding brake and contactor are controlled by exterior controller, not inverter.

1: Holding brake is controlled by inverter, and contactor is controlled by exterior controller.

2: Holding brake is controlled by exterior controller, and contactor is controlled by inverter.

3: Both holding brake and contactor is controlled by inverter.

Notice:

After holding brake and relay contactor is available, the corresponding time and fault of brake and contactor will be available.

Holding brake and contactor controlling are available in terminal control only.

Function Code	Name	Description	Setting range	Factory Setting
P8.05	Close brake delay time	0.00~5.00s	0.00~5.00s	0
P8.06	Open brake delay time	0.00~5.00s	0.00~5.00s	0

Close brake delay time is from 0 speed running to output close brake command. This parameter can enhance stop comfort.

Open brake delay time is from 0 speed running to output Open brake command. This parameter let inverter prevent starting concussion, before open brake.

Function Code	Name	Description	Setting Range	Factory Setting
P8.07	Brake threshold voltage	560.0~750.0V	560.0~750.0V	700.0

When the DC bus voltage is greater than the value of P8.07, the inverter will start dynamic braking.

Notice:

- **Factory setting is 380V if rated voltage of inverter is 220V.**
- **Factory setting is 700V if rated voltage of inverter is 380V.**
- **The value of P8.07 is corresponding to the DC bus voltage at rated input voltage.**

Function Code	Name	Description	Setting Range	Factory Setting
P8.08	Fault auto reset times	0~10	0~10	0
P8.09	Fault relay action	0~1	0~1	0
P8.10	Reset interval	0.1~100.0s	0.1~100.0s	1.0s

Auto reset function can reset the fault in preset times and interval. When P8.08 is set to be 0, it means "auto reset" is disabled and the protective device will be activated in case of fault.

P8.09 defines if fault relay active or not during auto reset. If continuous production without interruption is needed, please set P8.09=0.

Notice:

- **The fault such as OUT 1, OUT 2, OUT 3, OH1 and OH2 cannot be reset automatically.**
- **If fault has not occurred for ten minutes after the fault is reset, inverter will automatically clear the previous times of auto reset.**

Function Code	Name	Description	Setting Range	Factory Setting
P8.11	Brake feedback inspecting interval	0.1~5.0s	0.1~5.0s	2.0

After selecting brake control, the fault time of elevator brake action is more than P8.11, inverter will report brake feedback fault (FAE).

Detailed Function Description

Function Code	Name	Description	Setting Range	Factory Setting
P8.12	Contact feedback inspecting interval	0.1~5.0s	0.1~5.0s	2.0

After selecting contactor control, the fault time of elevator relay action is more than P8.12, inverter will report contactor feedback fault (TbE).

6.10 P9 Group -- Protection Parameters

Function Code	Name	Description	Setting Range	Factory Setting
P9.00	Input phase-failure protection	0: Disabled 1: Enabled	0~1	1
P9.01	Output phase-failure protection	0: Disabled 1: Enabled	0~1	1

Notice: Please be cautious to set these parameters as disabled. Otherwise it may cause inverter and motor overheat even damaged.

Function Code	Name	Description	Setting Range	Factory Setting
P9.02	Motor overload protection	0: Disabled 1: Normal motor 2: Variable frequency motor	0~2	2

1: For normal motor, the lower the speed, the poorer the cooling effect. Based on this reason, if output frequency is lower than 30Hz, inverter will reduce the motor overload protection threshold to prevent normal motor from overheat.

2: As the cooling effect of variable frequency motor has nothing to do with running speed, it is not required to adjust the motor overload protection threshold.

Function Code	Name	Description	Setting Range	Factory Setting
P9.03	Motor overload protection current	20.0%~120.0%	20.0~120.0	100.0%

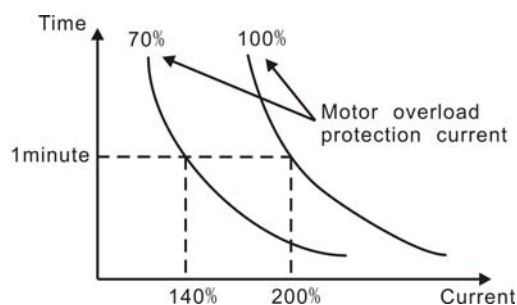

Figure 6.15 Motor overload protection curve.

The value can be determined by the following formula:

Motor overload protection current = (motor rated current / inverter rated current) * 100%

Notice:

- This parameter is normally used when rated power of inverter is greater than rated power of motor.
- Motor overload protection time: 60s with 200% of rated current. For details, please refer to above figure.

Function Code	Name	Description	Setting Range	Factory Setting
P9.04	Overload pre-warning threshold	20.0%~150.0%	20.0~150.0	130.0%
P9.05	Overload pre-warning selection	0: Always detect relative to motor rated current 1: Detect while constant speed relative to motor rated current 2: Always detect relative to inverter rated current 3: Detect while constant speed relative to inverter rated current	0~3	0
P9.06	Overload pre-warning delay time	0.0~30.0s	0.0~30.0	5.0s

The value of PB.05 determines the pre-warning category, such as motor overload (OL1) or inverter overload (OL2).

PB.04 determines the current threshold of pre-warning action, it is a percentage of the rated current. When output current of inverter exceeds the value of PB.04 and last the duration determined by PB.06, inverter will output a pre-warning signal. Please refer to following diagram:

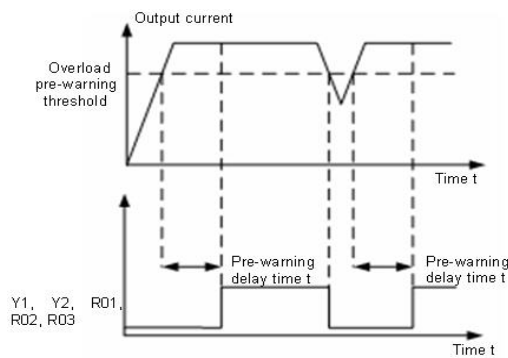

Figure 6.16 Overload pre-warning schematic diagram.

Function	Name	Description	Setting Range	Factory
----------	------	-------------	---------------	---------

Detailed Function Description

Code				Setting
P9.07	Inverter stop delay time	0.00~5.00s	0.00~5.00s	0.00s

When inverter controls brake, after close brake command is output, the stop command is given by exterior controller, at this time inverter will stop after the time of P9.07, it will protect elevator slide.

Notice: This function is only available in terminal control.

Function Code	Name	Description	Setting Range	Factory Setting
P9.08	Reserve function	0~65536	0	Reserve function

6.11 PA Group --Serial Communication

Function Code	Name	Setting Range
PA.00	Local communication address	0~247 【1】

When the master is writing the frame, if the communication address of the slave is set to be 0 (that is the broadcast communication address), all slaves on the MODBUS bus will receive the frame, but the slaves will not make any response. Note that the slave address should not be set to be 0.

The local communication address is a unique address in the communication network. This is the basis for point-to-point communications between the upper computer and the inverter.

Function Code	Name	Setting Range
PA.01	Communication baud rate selection	0~5 【4】

- 0: 1200BPS
- 1: 2400BPS
- 2: 4800BPS
- 3: 9600BPS
- 4: 19200BPS
- 5: 38400BPS

This parameter is used to set the data transmission rate between the upper computer and the inverter.

Notice: The baud rate setting of the upper computer should be the same as that of the inverter. Otherwise, communications cannot be implemented. The higher the baud rate, the faster the communication speed is.

Function Code	Name	Setting Range
PA.02	Data format	0~8 【1】

The data format setting of the upper computer should be the same as that of the inverter. Otherwise, communications cannot be implemented.

0: No parity (8,N,2) for RTU

1: Even parity (8,E,1) for RTU

2: Odd parity (8,O,1) for RTU

3: No parity (8,N,2) for ASCII

4: Even parity (8,E,1) for ASCII

5: Odd parity (8,O,1) for ASCII

6: No parity (7,N,2) for ASCII

7: Even parity (7,E,1) for ASCII

8: Odd parity (7,O,1) for ASCII

Function Code	Name	Setting Range
PA.03	Communication reply delay	0~20ms 【0ms】

Reply delay: refers to the interval time between the end of data receiving of the inverter and the reply data sending of the upper computer. If the reply delay time is less than the system processing time, take the system processing time as reply delay reference. If the reply delay is longer than the system processing time, after data processing, the system has to wait until the reply delay time is reached before sending data to the upper computer.

Function Code	Name	Setting Range
PA.04	Communication timeout fault time	0.0~100.0 【0.0s】

If the functional code is set to 0.0s, the communication delay time parameter is disabled. When the functional code is set to be a valid value, if the interval between the current communication and the next communication exceeds the communication delay time, the system will send a communication fault error (Err18).

Normally, it is set to be "disabled". If this parameter is set in a consecutive communication system, communication status can be monitored.

Function Code	Name	Setting Range
PA.05	Communication reply enabled selection	0~1 【0】

0: communication reply enabled

Detailed Function Description

1: communication reply disabled

Selecting whether replying or not to master command.

Function Code	Name	Setting Range
PA.06	Reserved	1~127 【1】
PA.07	Reserved	0~6 【4】
PA.08	Reserved	0~65535 【0】

CAN communication is reserved.

6.12 PB Group -- Distance Control

Function Code	Name	Setting Range
PB.00~PB.99	Reserved	Distance control reserved function

6.13 PE Group --Factory Setting

This group is the factory-set parameter group. It is prohibited for user to access.

7. DESCRIPTION OF CHV 180'S EXTENSION CARD

7.1 Description of communication card

7.1.1 Model

The model of CHV180's communication card is PN000TXWX, and it is compatible with CHV's extension card. This card provides two modes for communicating, which are RS232 and RS485.

7.2 Installation

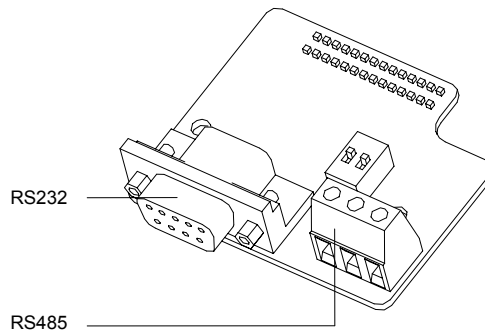

Figure 7.1 Communication card.

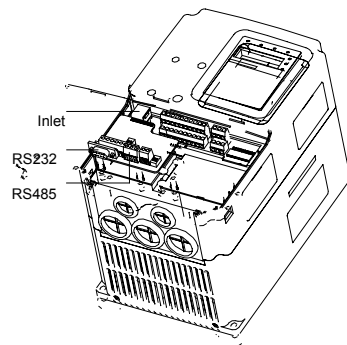

Figure 7.2 Installation of communication card.

7.1.3 Application of communication card

Description of CHV180's Extension Card

If need to use CHV 180 inverters and upper computer (PLC, industrial PC), the user must choose this communication card. It provides two physical communication modes (RS232 and RS485). The electric parameters can meet the related international standards completely and can implement smooth communications between CHV inverter and upper computer system. Please choose the corresponding physical channel according to the actual applications.

7.1.4 Wiring Terminals

The communication card has two groups of wiring terminals, as shown in Figure 7.3.

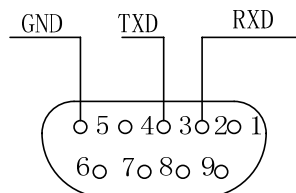

Figure 7.3 D9: Bus-connector wiring terminal

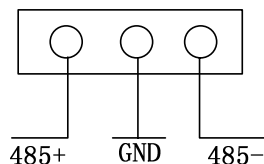

Figure 7.4 RS485 wiring terminal

7.1.5 Precautions of Wiring

- Please install this card after the inverter is completely powered off.
- Please make perfect connection between the communication card and the extension slot of control card.
- Use screws to fix the communication card.
- To prevent communication signals from external disturbance, please choose twisted pairs as communication line, and try to avoid parallel wiring with the drive power.
- It is better to choose the shielded cable as RS232 communication line.

7.2 Description of I/O extension card

7.2.1 Description of I/O extension card terminal and jumper

(1) Terminals

Terminal	Description
S7~S10	ON-OFF signal input, optical coupling with PW and COM Input voltage range: 9~30V Input impedance: 3.3KΩ
COM	Common ground terminal for +24V or exterior power
GND	Common ground terminal of +10V
Y2	Open collector output terminal, the corresponding common ground output terminal is CME

Description of CHV180's Extension Card

	Exterior voltage range: 0~24V Output current range: 0~50mA
CME2	Open collector output common terminal
AO2	Analog quantity output terminal Output range: 0~10V/0~20mA (select voltage or current output can be switched by J2)
RO3A、RO3B、RO3C	Relay output: RO3A common, RO3B NC, RO3C NO Contact capacity: AC250V/3A, DC30V/1A
RS485+、RS485-	RS485 Communication
CANH、CANL	CAN communication ports (reserved)

Notice: GND must isolate from COM.

(2) Jumper

J1	1 connect to 2 means paralleling a 120Ω matching resistance for CAN control output terminal, 2 and 3 are be hanged in the air
J2	Switch between 0~10V coltage input or 0~20mA current input 1 (V) connect to 2 (GND) means voltage input; 2 (GND) connect to 3 (I) means current inout
S1	Selection of RS485 communication terminal organ setting. ON: enable terminal organ; OFF: forbidden terminal organ When the port of RS485 is at the end of RS485 communication network cable, that need enable terminal organ

7.2.2 Description of dimension and terminal compositor

(1) Dimension of I/O extension card and sketch map for CHV180

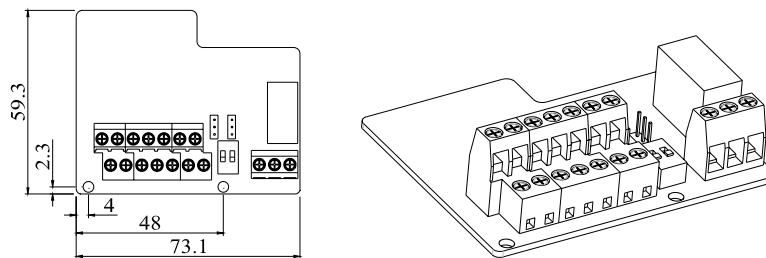

Figure 7.5 Dimension of I/O extension card.

(2) Sketch map of terminal compositor

S7	S8	S9	S10	GND	CANH	CANL			
COM	COM	CME2	Y2	A02	RS485+	RS485-	R03A	R03B	R03C

7.2.3 Installation of I/O extension card for CHV180

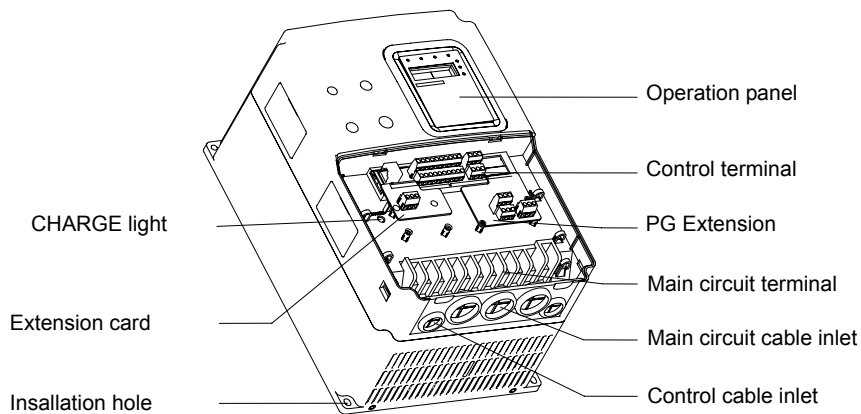

Figure 7.6 Installation of of I/O extension card and PG card.

7.3 Description of asynchronous motor PG card

7.3.1 Model and specifications

The model of PG card for CHV180 inverters is PN000PGWX. The technical features are as follow:

Terminal	Technical features
12V、COM1	Encoder power supply, maximum output current is 300mA
TERA+、TERA-、 TERB+、TERB-	Encoder signal input access Voltage range: 12~15V Response speed: 0~80kHz
TER-OA TER-OB	Frequency output: 0~80kHz Output impedance: 30Ω Frequency division range: 1~256

7.3.1.2 Dimensions and Installation

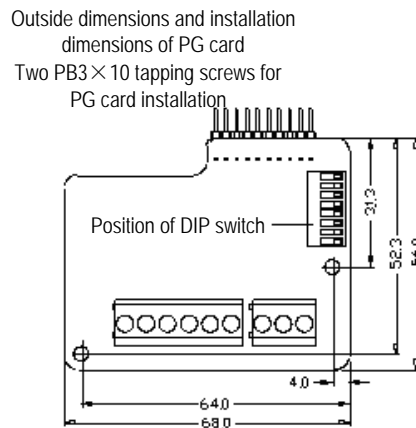
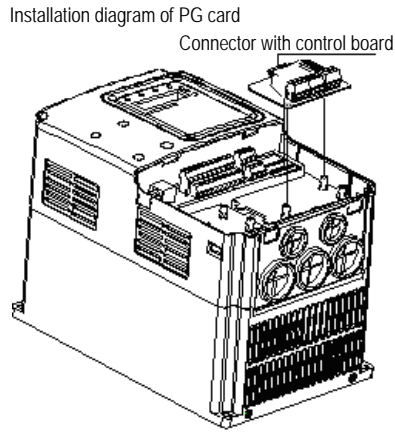

Figure 7.7 Installation and Dimensions of PG Card.

NOTICE: The contact pin of PG card is inserted into the below connector with control board CN9.

7.3.2 Operating Instructions of asynchronous motor PG card

7.3.2.1 Functions

If the user requires PG vector control, need to select PG card. The function of the PG card includes processing circuits for two channels of orthogonal coder signals, capable of receiving signals from differential output, open-circuit collector output and push-pull output encoders, Coder power supply (+12V output, adjustable through the

Description of CHV180's Extension Card

potentiometer on the PG card). In addition, it can output in frequency-division the inputted encoder signals (output are two channels of orthogonal signals). The user can make selection according to actual situations.

7.3.2.2 Description of Terminals and DIP Switch

The PG card has nine wiring terminals, as shown in Figure 7.7.

+12V	COM1	TERA+	TERA-	TERB+	TERB-	TER-OA	TER-OB	COM1
------	------	-------	-------	-------	-------	--------	--------	------

Figure 7.8 User Wiring Terminals of PG Card.

Where, +12V and COM1 are working voltage output for the coder; TERA+, TERA-, TERB+, and TERB- are signal input terminals for the coder; TER-OA, TER-OB, and COM1 are output terminals for frequency-division signals; PE is the wiring terminal for shielding cable (PE inside the PG card is not connected to the ground, and the user can connect it to the ground during use).

The frequency division factor is determined by the DIP switch on the card. The DIP switch consists of 8 bits. When the binary digits are displayed by DIP switch pluses 1, the relative value is frequency division factor. The bit marked as "1" on the DIP switch is the lower binary bit, while "8" is the higher binary bit. When the DIP switch is switched to ON, the bit is valid, indicating "1"; otherwise, it indicates "0".

Frequency division factors are shown in the table below:

Decimal Digit	Binary Digit	Frequency Division Factor
0	00000000	1
1	00000001	2
2	00000010	3
...
m	...	m+1
255	11111111	256

7.3.2.3 Wiring Diagram

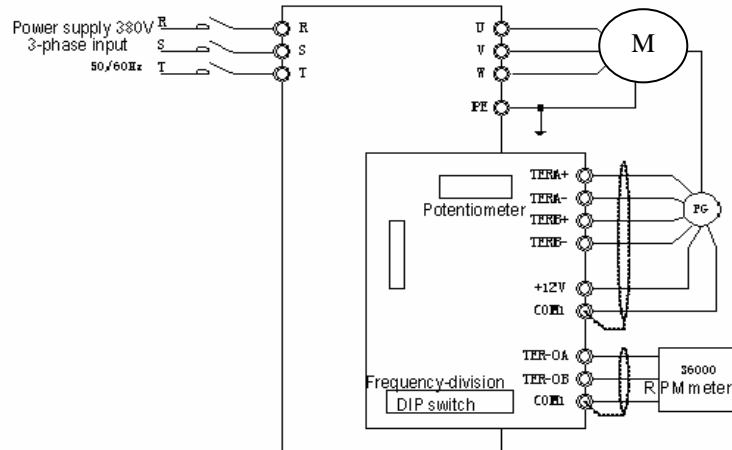

Figure 7.9 PG Card Wiring Diagram.

7.3.2.4 Precautions on Wiring

- The signal line of PG card should be separated from the power line. Parallel wiring is forbidden.
- To prevent coder signals from disturbance, please select a shielded cable as the signal line of PG card.
- The shielding layer of shielded cable of PG card should be grounded (such as terminal PE of the inverter), and furthermore, only one end is grounded, to prevent signal from disturbance.
- If the frequency-division output of PG card is connected to user power supply, the voltage should be less than 24V; otherwise, the PG card may be damaged.

7.3.3 Application Connection

(1) Wiring Diagram of Differential Output Coder

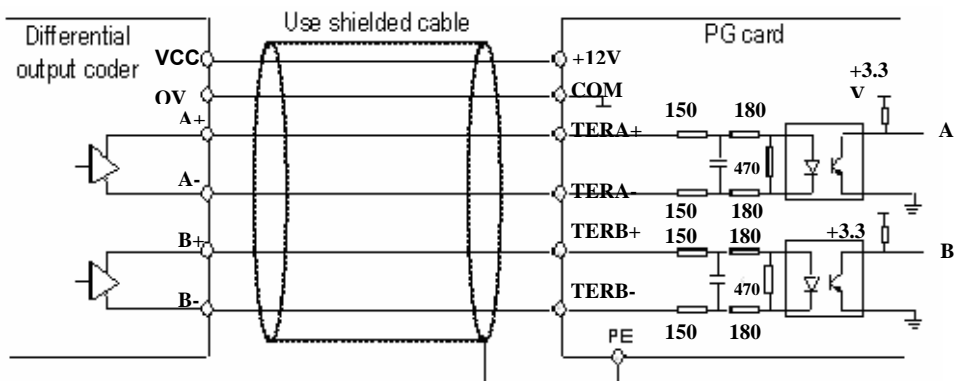

Figure 7.10 Wiring Diagram of Differential Output Coder.

(2) Wiring Diagram of Open Collector Output Coder

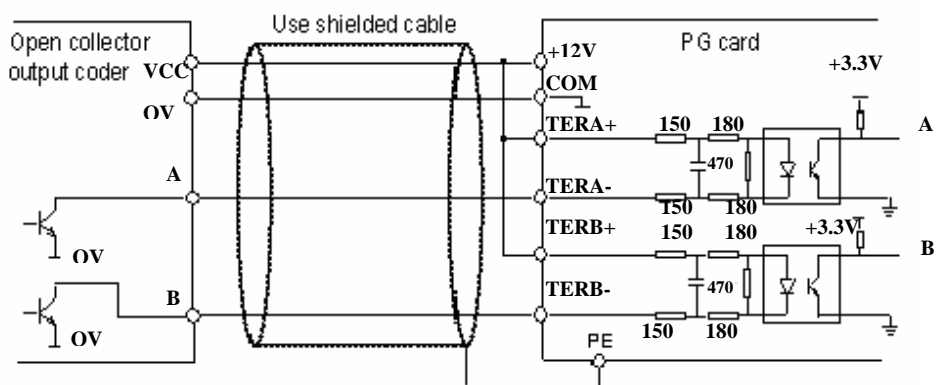

Figure 7.11 Wiring Diagram of Open Collector Output Coder.

(3) Wiring Diagram of Push-pull Output Coder

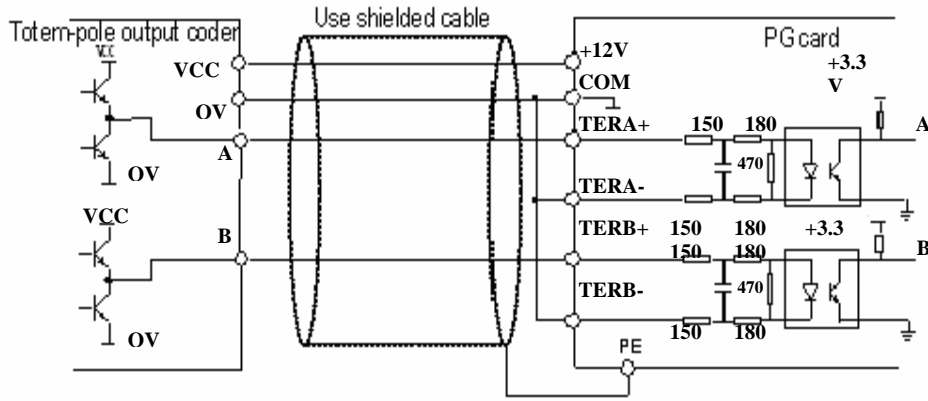

Figure 7.12 Wiring Diagram of Push-pull Output Coder.

(4) Wiring Diagram of PG Card Frequency-division Output

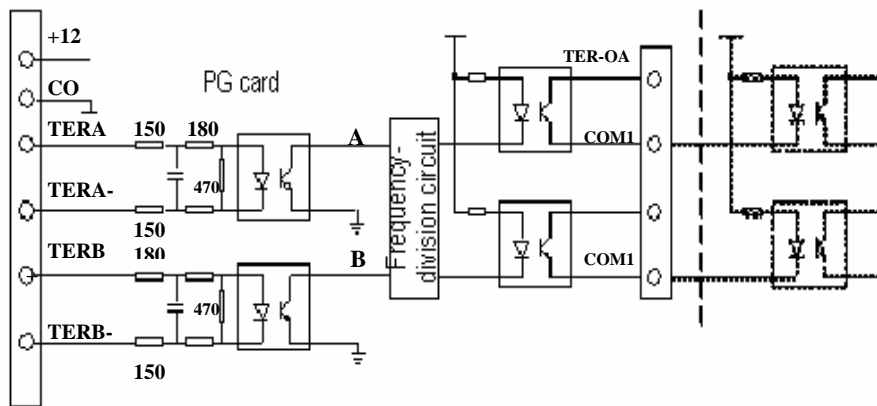

Figure 7.13 Wiring Diagram of PG Card Frequency-division Output.

7.4 Description of synchronous motor PG card

7.4.1 Model and specifications

The model of PG card for CHV180 inverters is ASY-2010-T. The technical features are as follow:

Description of CHV180's Extension Card

Terminal	Technical features
+5V	Encoder power, the maximum output current is 130mA
The types of support encoder	The SIN/COS and UVW encoder is supported, and the signal is differential input.
Respond speed	0~80kHz
TER-OA、TER-OB	Output frequency: 0~80kHz Output impedance: 30Ω Frequency Division range: 1~256

7.4.2 Dimensions and Installation

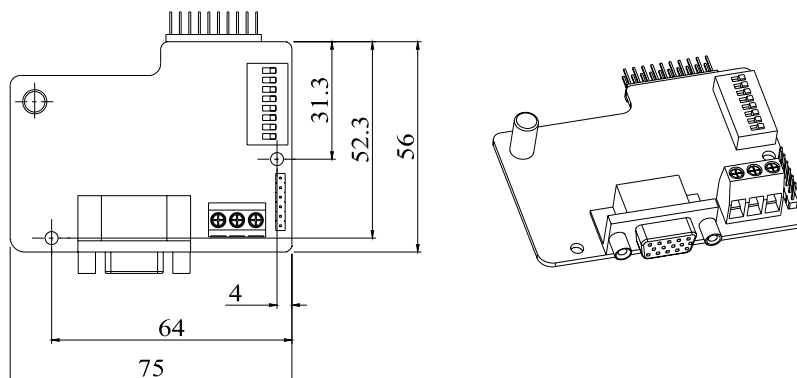

Figure 7.14 Dimension and installation of synchronous motor PG card.

Notice: The position and method of synchronous motor PG card are the same as the asynchronous motor PG card, but the contact pin has two lines, the contact pin of asynchronous motor PG card is only one line.

The PG card of asynchronous motor is the same as all of CHV series inverters, but the PG card of synchronous motor is only used to CHV180 inverter. When user is using the synchronous tractor, they must select the PG card of synchronous motor. The PG card is compatible with SIN/COS and UVW encoder, the output power supply is +5V, and the precision is $\pm 5\%$. At the same time, it can go to frequency division output to input signal of encoder. The user can select it according to the practical situation.

7.4.3 Description of Terminals and DIP Switch

The PG card has one signal wire port and there user wire ports. As shown in Figure 7.15:

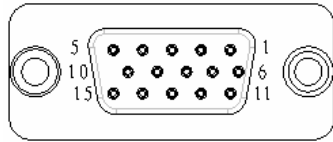

TER- OA	TER- OB	COM1
------------	------------	------

DB15

Frequency division output

Figure 7.15 The PG card wire port and wire terminals.

TER-OA、TER-OB、COM1 are the signal frequency division output terminals.

NOTICE : The PG card has not PE terminal , user must connect the card to earth.

DB15 is the port of the encoder input signal. The order of the ports signal is as follow:

Port	SIN/COS	UVW
8	A	A
3	A-	A-
9	B	B
4	B-	B-
15	R	Z
14	R-	Z-
6	C	U
1	C-	U-
7	D	V
2	D-	V-
12	5V	5V
13	0V	0V
10	Empty	W
5	Empty	W-
11	Empty	Empty

When user apply the PG card, you only need to let the corresponding connecting wire with UVW encoder signal array and the PG card signal array insert to DB15.

The frequency division factor is determined by the DIP switch on the card. The DIP switch consists of 8 bits. When the binary digits are displayed by DIP switch plus 1, the relative value is frequency division factor. The bit marked as "1" on the DIP switch is the lower binary bit, while "8" is the higher binary bit. When the DIP switch is switched to ON, the bit is valid, indicating "1"; otherwise, it indicates "0".

Frequency division factors are shown in the table below:

Description of CHV180's Extension Card

Decimal Digit	Binary Digit	Frequency Division Factor
0	00000000	1
1	00000001	2
2	00000010	3
...
m	...	m+1
255	11111111	256

8. DESCRIPTION OF DEBUGGING ELEVATOR

8.1 Runing and adjusting parameter

After adjusting application parameters, you must check all parameters according to function requirement, especially the parameters that is interrelated to wiring of inverter periphery, such as operation mode, control mode, setting of Programmable input/output and selecting of feedback quantity, you must check these paramters, and then go to debug system runing. Debug runing is composed of Motor parameters autotuning, overhaul runing, S-curve of good runing adjusting, comfort of elevator on-off adjusting and precision of elevator flat bed adjusting.

8.1.1 Motor parameters autotuning

Before beginning to debug elevator, we suggest that user should go to autotune for tractor parameters. During autotuning, do not connect any load to the motor at first, and adjust P0.17 to be 1, then go to motor parameters autotuning according to the description of P0.08.

Notice: It is different to the motor parameters autotuning of synchronous motor and asynchronous motor.

8.1.2 Overhaul runing

Overhaul runing is used to judge whether the elevator is good runing.

During overhaul runing, we should pay attention to actual runing direction of elevator in accordance with ordering direction, if them are discordant, we can change the wiring between the output terminal (U,V,W), or adjust P0.06 to be 1.

Notice: we suggest that user should adjust P0.06 to change elevator runing direction for synchronous motor.

8.1.3 S-curve adjusting

Before good runing, we should judge whther the control logic is right, and wiring is right. If these are right, we can go to adjust S-curve. We can adjust S-curve according to the description of P1.08~P1.15.

8.1.4 Comfort of elevator on-off adjusting

We set the next parameters to change the comfort of elevator starting: P1.14 (starting speed), P1.15 (hold time of starting speed), P1.08 (starting quadric acceleration), P1.09 (starting acceleration), P3.00 and P3.01 (PI parameter of low speed), P8.06 (contracting brake open delay time). If you have used a weighing equipment of analog quantity, you

need to adjust Precompensation of Starting moment, the adjusting way is talked on the description of themselves.

We set the next parameters to change the comfort of elevator stopping: P1.12 (stopping quadric deceleration), P1.13 (stopping deceleration), P3.00 and P3.01 (PI parameter of low speed), P8.06 (contracting brake close delay time).

8.1.5 Accuracy of Elevator flat floor adjusting

When the error of flat floor on every floor is not same, you will adjust the position of flashboard on every floor to keep the same errors on every floor. After the error is same, we can adjust creeping speed of elevator and P1.12 (stopping deceleration time).

8.2 Elevator runing mode

There are two ways for CHV180, Multi-step Speed and analog quantity speed. In fact, the Multi-step Speed is the main way.

8.2.1 Multi-step Speed mode

Multi-step Speed mode is that the output frequency can be changed by multi-step terminals. As in the next project of elevator control: contracting brake and contrator are controlled by inverter, examining contracting brake, feedback signal of contractor and examine command are controled by terminal (EXM). Run speed is setted by MS1~MS3, and setted by analog quantity of weighing equipment.

Wiring diagram is as follows:

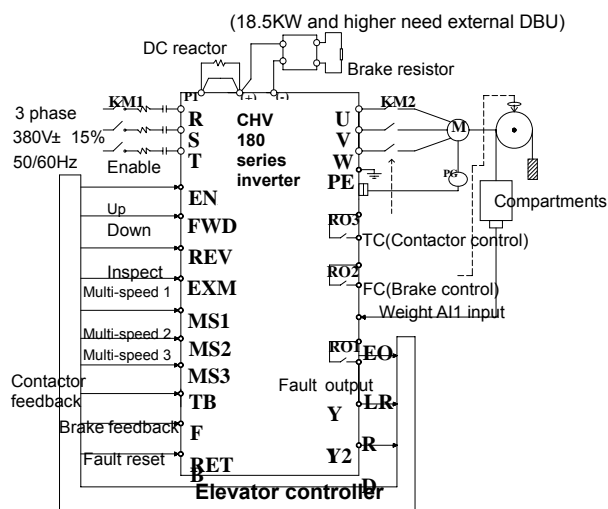

Figure 8.1 Wiring principle for Multi-step speed control.

Sequence chart of running is as follows:

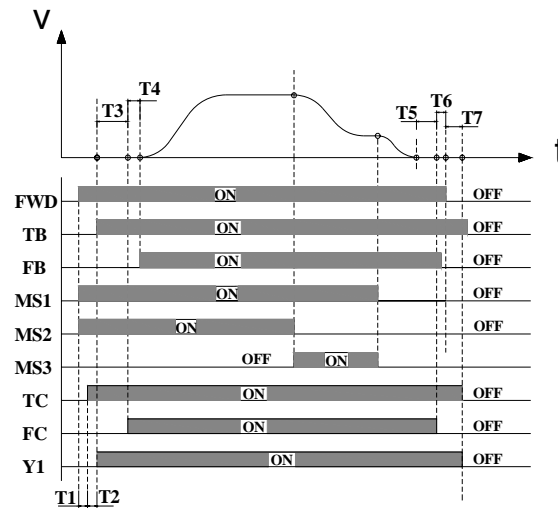

Figure 8.2 Sequence chart of running for Multi-step speed control.

In this chart, the meanings of T1~T7 are as follows:

Sign	Meanings
T1	The time is the system delay time from inverter received running signal to output pick-up command of contactor.
T2	The time is the wait delay time form inverter output contactor pick-up command to receive contactor feedback signal.
T3	P8.06 (contacting brake close delay time)
T4	The time is the wait delay time form inverter output brake command to receive brake feedback signal.
T5	P8.05 (contacting brake open delay time)
T6	The time is the wait delay time from inverter output close command to receive stopping command of external control.
T7	P9.09 (inverter stop delay time)

The description of sequence chart:

1. After inverter receive the running command (FWD) and running speed command (MS1~MS3), delay the time of T1, the inverter output contactor pick-up command (TC).
2. After the time of T2, after the inverter check the pick-up signal of contactor (TB), the

Description of Debugging Elevator

- inverter is running at 0 speed, at the same time the inverter running signal (Y1) output. After the time of T3, the inverter output contactor brake close signal (FC).
3. After the time of T4, the inverter checked the feedback signal of brake, after affirming brake is open, the inverter is accelerated running with S-curve.
 4. After the controller cut off the speed command (MS1~MS3), the inverter is decelerated stopping with S-curve. After the speed runs to 0, and the time of T5, the inverter output the command of brake open (FC), and can cut off running command.
 5. After the time of T6, and it receives the stop command, and after the time of T7, the inverter is stop, at the same time the inverter output cutting contactor command(TC) and stop signal of elevator. At this time, one operation cycle is over.

Detailed functions of multi-step speed mode are as follows:

Function	Name	Recommendation setting	Remark
P0.00	Speed control mode	1	Vector control With PG
P0.01	Run command source	1	Terminal control
P0.02	Rating speed of elevator	1.500m/s	User setting
P0.03	Speed command source	3	Multi-step Speed
P0.04	Maximum frequency	50.00Hz	User setting
P1.00	Multi-step Speed 0	0	Setting parameters according to user's needs, and set Multi-step speed 0 to be 0 among them.
P1.01	Multi-step Speed 1	Re-flatlayer speed	
P1.02	Multi-step Speed 2	Creeping speed	
P1.03	Multi-step Speed 3	Urgency speed	
P1.04	Multi-step Speed 4	Reserved	
P1.05	Multi-step Speed 5	Normal low speed	
P1.06	Multi-step Speed 6	Normal high speed 1	
P1.07	Multi-step Speed 7	Normal high speed 2	
P1.08	Start acceleration of acceleration	0.350m/s ³	Set by on-site debugging
P1.09	Start acceleration	0.700m/s ²	
P1.10	Speed-down deceleration of	0.350m/s ³	

deceleration of

	deceleration		
P1.11	Deceleration	0.700m/s ²	
P1.12	Stop deceleration of deceleration	0.350m/s ³	
P1.13	Stop deceleration	0.700m/s ²	
P1.14	Start speed	0.000m/s	
P1.15	Start speed holding time	0.0s	
P1.16	Overhaul run speed	0.300m/s	
P1.17	Overhaul run acceleration	1.000 m/s ²	
P1.18	Overhaul run deceleration	1.000 m/s ²	
P2.00	Motor type source	Affirm the type of motor	
P2.01	Tractive roller diameter	Tractor nameplate	Set by tractor nameplate
P2.02	Reduction ratio	Tractor nameplate	
P2.03	Suspension ratio	Tractor nameplate	
P2.04	Motor rated power	Tractor nameplate	
P2.05	Motor rated frequency	Tractor nameplate	
P2.06	Motor rated speed	Tractor nameplate	
P2.07	Motor rated voltage	Tractor nameplate	
P2.08	Motor rated current	Tractor nameplate	
P3	Vector control	Recommendation setting	Set by running effect
P4.00	Encoder type source	Affirm the type of encoder	Set by encoder
P4.01	Number of pulse of encoder		
P4.02	Encoder direction	0	Set by result of debugging
P5.02	S1 terminal function	1	Up run (FWD)
P5.03	S2 terminal function	2	Down run (REV)
P5.04	S3 terminal function	8	Multi-step Speed reference 1

Description of Debugging Elevator

			(MS1)
P5.05	S4 terminal function	9	Multi-step Speed reference 2 (MS2)
P5.06	S5 terminal function	3	Overhaul run (EXM)
P5.07	S6 terminal function	19	Inverter enable (ENA)
P5.08	S7 terminal function	10	Multi-step Speed reference 3 (MS3)
P5.09	S8 terminal function	17	Contractor feedback 0 (TB)
P5.10	S9 terminal function	18	Contracting brake feedback (FB)
P5.11	S10 terminal function	6	Fault reset (RET)
P6.01	Y1 output selection	1	Elevator running (LR)
P6.02	Y2 output selection	6	Run is all set (RD)
P6.04	Relay 1 output	4	Fault output (EO)
P6.05	Relay 2 output	7	Contracting brake control (FC)
P6.06	Relay 3 output	8	Relay control (TC)
P8.00	Analog weigh signal input selection	1	Input channel of analog weigh is AI1
P8.01	Beforehand torque excursion	30%	Set by counterpoise and relatively weight of litter
P8.02	Drive side plus	1.000	
P8.03	Trig side plus	1.000	
P8.04	Brake and contactor control selection	3	Inverter control contracting brake and relay
P8.05	Brake close delay time	0.0s	Set by on-site debugging
P8.06	Brake open delay time	0.0s	
P8.11	Brake feedback check time	2.0	
P8.12	Relay feedback check time	2.0	
P9.07	Delay time of stopping	0.0	

NTICE: If the inverter is running with Multi-step Speed, the Multi-step Speed 0 must be set to be 0.

8.2.2 Analog quantity speed mode

Analog quantity speed mode is that speed is set by analog quantity, and the inverter only runs with analog quantity signal, and the run curve of elevator is decided by analog quantity variation curve generated by external controller. The tractor is only driven by inverter, and the comfort has nothing to do with inverter. The channel of analog quantity can select AI1 or AI2.

The wiring diagram of analog quantity speed mode is as follow:

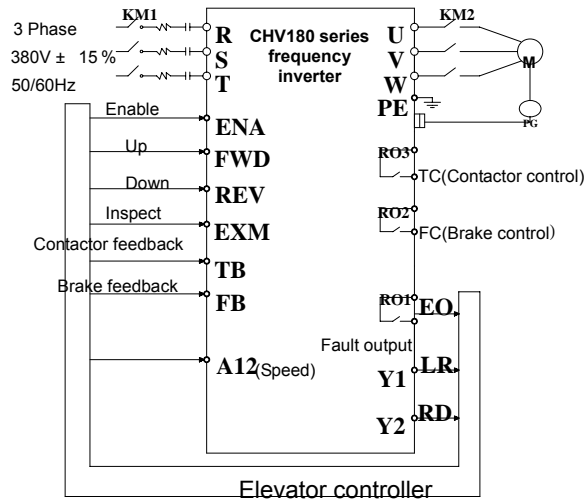

Figure 8.3 Wiring diagram of analog quantity mode.

The time sequence:

The time sequence is the same as Multi-step Speed's on the whole. For detailed description, please refer to Figure 8.2.

Function	Name	Recommendation setting	Remark
P0.00	Speed control mode	1	Vector control with PG
P0.01	Run command source	1	Terminal control
P0.02	Rating speed of elevator	1.500m/s	User setting

Description of Debugging Elevator

P0.03	Speed command source	2	AI2
P0.04	Maximum frequency	50.00Hz	User setting
P1.16	Overhaul run speed	0.300m/s	
P1.17	Overhaul run acceleration	1.000 m/s ²	
P1.18	Overhaul run deceleration	1.000 m/s ²	
P2.00	Motor type source	Affirm the type of motor	Set by tractor nameplate
P2.01	Tractive roller diameter	Tractor nameplate	
P2.02	Reduction ratio	Tractor nameplate	
P2.03	Suspension ratio	Tractor nameplate	
P2.04	Motor rated power	Tractor nameplate	
P2.05	Motor rated frequency	Tractor nameplate	
P2.06	Motor rated speed	Tractor nameplate	
P2.07	Motor rated voltage	Tractor nameplate	
P2.08	Motor rated current	Tractor nameplate	
P3 Group	Vector control	Recommendation setting	Set by running effect
P4.00	Encoder type source	Affirm the type of encoder	Set by encoder
P4.01	Number of pulse of encoder		
P4.02	Encoder direction	0	Set by result of debugging
P5.02	S1 terminal function	1	Up run (FWD)
P5.03	S2 terminal function	2	Down run (REV)
P5.04	S3 terminal function	3	Overhaul run (EXM)
P5.05	S4 terminal function	19	Inverter enable (ENA)
P5.06	S5 terminal function	10	Multi-step Speed reference 3 (MS3)
P5.07	S6 terminal function	17	Relay feedback (TB)
P5.08	S7 terminal function	18	Contracting brake feedback (FB)

P5.09	S8 terminal function	6	Fault reset (RET)
P6.01	Y1 output selection	1	Elevator running (LR)
P6.02	Y2 output selection	6	Run is all set (RD)
P6.04	Relay 1 output	4	Fault output (EO)
P6.05	Relay 2 output	7	Contracting brake control (FC)
P6.06	Relay 3 output	8	Relay control (TC)
P8.00	Analog weigh signal input selection	1	Input channel of analog weigh is AI1
P8.01	Beforehand torque excursion	30%	Set by counterpoise and relatively weight of litter
P8.02	Drive side plus	1.000	
P8.03	Trig side plus	1.000	
P8.04	Brake and contactor control selection	3	Inverter control contracting brake and relay
P8.05	Brake close delay time	0.0s	Set by on-site debugging
P8.06	Brake open delay time	0.0s	
P8.11	Brake feedback check time	2.0	
P8.12	Contactor feedback check time	2.0	
P9.07	Delay time of stopping	0.0	

NOTICE:

When the speed is set by analog quantity, the S-curve of inner inverter is invalid. The run curve of elevator is generated by external controller. Setting the parameter P5.17 or P5.22, analog quantity filter time, will influence the sensitivity of analog quantity input.

If the change rate of analog quantity is too large, the run frequency of inverter will be break, and it will let inverter be over-current or over-voltage.

8.2.3 Overhaul running

The wiring diagram of overhaul run mode is as follow:

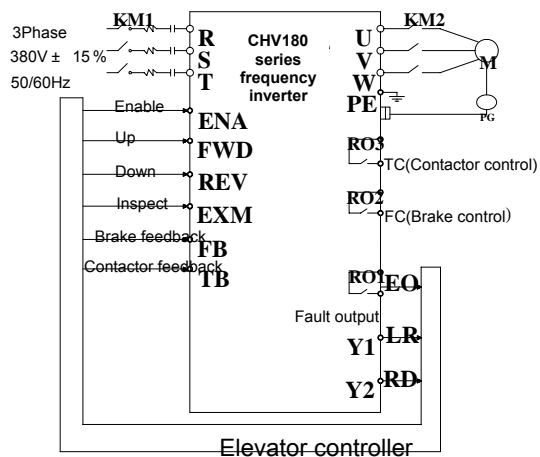

Figure 8.4 Wiring diagram of overhaul run mode.

Sequence chart of overhaul running is as follows:

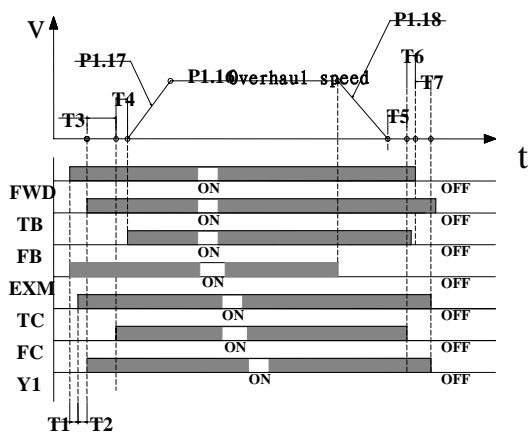

Figure 8.5 Sequence chart of overhaul running.

In this chart, the meanings of T1~T7 are as follows:

Sign	Meanings
T1	The time is the system delay time from inverter received running signal to output pick-up command of contactor.
T2	The time is the wait delay time form inverter output contactor pick-up command to receive contactor feedback signal.
T3	P8.06 (contacting brake close delay time)
T4	The time is the wait delay time form inverter output brake command to receive brake feedback signal.
T5	P8.05 (contacting brake open delay time)
T6	The time is the wait delay time from inverter output close command to receive stopping command of external control.
T7	P9.09 (inverter stop delay time)

1. After inverter receive the running command (FWD) and overhaul command (EXM), delay the time of T1 (4ms), the inverter output contactor pick-up command (TC).
2. After the time of T2, after the inverter check the pick-up signal of contactor (TB), the inverter is running at 0 speed, at the same time the inverter running signal (Y1) output. After the time of T3, the inverter output brake close signal (FC).
3. After the time of T4, the inverter checked the feedback signal of brake, after affirming brake is all open, the inverter is accelerated running with overhaul run acceleration (P1.17).
4. After the controller cut off the overhaul command (EXM), the inverter is decelerated stopping with overhaul run deceleration (P1.18). After the speed runs to 0, and the time of T5, the inverter output the command of contracting brake open (FC), and can cut off running command.
5. After the time of T6, and it receive the stop command, and after the time of T7, the inverter is stop, at the same time the inverter output cutting of contactor command (TC) and stop signal of elevator (Y1). At this time, one operation cycle is over.

8.2.4 Emergency running

The wiring diagram of emergency run is as follows:

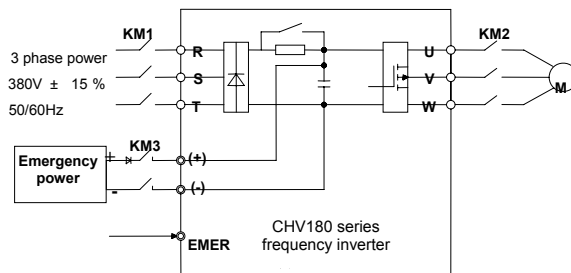

Figure 8.6 Wiring diagram of emergency run.

Definition of terminal is as follow:

Terminal sign	Meanings
EMER	Emergency run
FWD	Up running elevator
REV	Down running elevator
(+), (-)	Bus voltage terminal of inverter
KM	Control contactor of main power
KM3	Control contactor of emergency power

Sequence chart of emergency run is as follows:

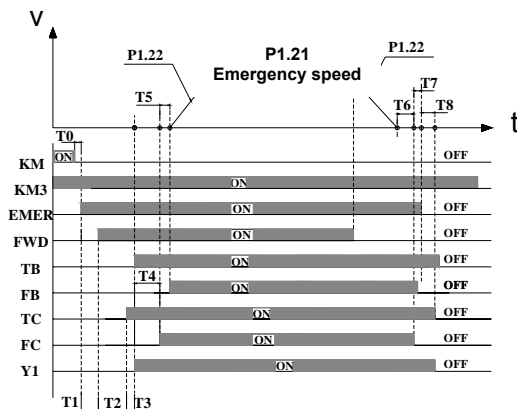

Figure 8.7 Sequence chart of emergency run.

In this chart, the meanings of T0~T8 are as follows:

Symbol	Description
T0	The time is the delay time from the inverter's power-off to open the switch of emergency power
T1	The time is the delay time from the controller output emergency command to output run command
T2	The time is the system delay time from inverter received running signal to output pick-up command of contactor.
T3	The time is the wait delay time form inverter output contactor pick-up command to receive contactor feedback signal.
T4	P8.06 (contacting brake close delay time)
T5	The time is the wait delay time form inverter output brake command to receive brake feedback signal.
T6	P8.05 (contacting brake open delay time)
T7	The time is the wait delay time from inverter output close command to receive stopping command of external control.
T8	P9.09 (inverter stop delay time)

1. When the main power is power-off, the controller cut off main power relay (KM1), after the time of T0, the control switch of emergency power will be closed, and output emergency command, after the time of T1, the inverter receives running command from controller, then after the system time of T2, the inverter output closed command of contactor.
2. After the time of T3, the inverter detect closed signal (TB) of contactor, then the inverter start to run with zero speed, at the same time output running signal (Y1). After the time of T4, the inverter output brake closed signal (FC).
3. After the time of T5, the inverter detect brake feedback signal(FB), after affirming the brake open, the inverter accelerate to emergency speed (P1.21) with emergency acceleration (P1.22), then run with constant rate.
4. When elevator run to flat bed, the controller will cut off emergency command (EMER), and the inverter begin to decelerate to stop with emergency deceleration (P1.22), after the time of T6, the inverter output brake open command (FC), and the controller cut off running command.
5. After the time of T7, the inverter receive stop command, and then repass the time of T8, the inverter stop, and ouput open command (TC) of contactor and stop signal (Y1) of elevator. At this time, one operation cycle is over.

9. TROUBLE SHOOTING

9.1 Fault and trouble shooting

Fault Code	Fault Type	Reason	Solution
OUT1	IGBT Ph-U fault	1. Acc/Dec time is too short. 2. IGBT module fault. 3. Malfunction caused by interference. 4. Grounding is not properly.	1. Increase Acc/Dec time. 2. Ask for support. 3. Inspect external equipment and eliminate interference.
OUT2	IGBT Ph-V fault		
OUT3	IGBT Ph-W fault		
OC1	Over-current when acceleration	1. Short-circuit or ground fault occurred at inverter output. 2. Load is too heavy or Acc/Dec time is too short. 3. V/F curve is not suitable. 4. Sudden change of load.	1. Inspect whether motor damaged, insulation worn or cable damaged. 2. Increase Acc/Dec time or select bigger capacity inverter. 3. Check and adjust V/F curve. 4. Check the load.
OC2	Over-current when deceleration		
OC3	Over-current when constant speed running		
OV1	Over-voltage when acceleration	1. Dec time is too short and regenerative energy from the motor is too large. 2. Input voltage is too high.	1. Increase Dec time or connect braking resistor 2. Decrease input voltage within specification.
OV2	Over-voltage when deceleration		
OV3	Over-voltage when constant speed running		
UV	DC bus Under-voltage	1. Open phase occurred with power supply. 2. Momentary power loss occurred 3. Wiring terminals for input power supply are loose. 4. Voltage fluctuations in power supply are too large.	Inspect the input power supply or wiring.

Fault Code	Fault Type	Reason	Solution
OL1	Motor overload	<ol style="list-style-type: none"> 1. Motor drive heavy load at low speed for a long time. 2. Improper V/F curve 3. Improper motor's overload protection threshold (PB.03) 4. Sudden change of load. 	<ol style="list-style-type: none"> 1. Select variable frequency motor. 2. Check and adjust V/F curve. 3. Check and adjust PB.03 4. Check the load.
OL2	Inverter overload	<ol style="list-style-type: none"> 1. Load is too heavy or Acc/Dec time is too short. 2. Improper V/F curve 3. Capacity of inverter is too small. 	<ol style="list-style-type: none"> 1. Increase Acc/Dec time or select bigger capacity inverter. 2. Check and adjust V/F curve. 3. Select bigger capacity inverter.
SPI	Input phase failure	<ol style="list-style-type: none"> 1. Open-phase occurred in power supply. 2. Momentary power loss occurred. 3. Wiring terminals for input power supply are loose. 4. Voltage fluctuations in power supply are too large. 5. Voltage balance between phase is bad. 	Check the wiring, installation and power supply.
SPO	Output phase failure	<ol style="list-style-type: none"> 1. There is a broken wire in the output cable 2. There is a broken wire in the motor winding. 3. Output terminals are loose. 	Check the wiring and installation.
OH1	Rectify overheat	<ol style="list-style-type: none"> 1. Ambient temperature is too high. 2. Near heat source. 3. Cooling fans of inverter stop or damaged. 	<ol style="list-style-type: none"> 1. Install cooling unit. 2. Remove heat source. 3. Replace cooling fan 4. Clear the ventilation channel.
OH2	IGBT overheat	<ol style="list-style-type: none"> 4. Obstruction of ventilation channel 5. Carrier frequency too high. 	<ol style="list-style-type: none"> 5. Decrease carrier frequency.
EF	External fault	Sx: External fault input terminal take effect.	Inspect external equipment.
CE	Communication fault	<ol style="list-style-type: none"> 1. Improper baud rate setting. 2. Receive wrong data. 3. Communication is interrupted for Long time 	<ol style="list-style-type: none"> 1. Set proper baud rate. 2. Check communication devices and signals.

Trouble Shooting

Fault Code	Fault Type	Reason	Solution
ITE	Current detection fault	1. Wires or connectors of control board are loose 2. Hall sensor is damaged. 3. Amplifying circuit is abnormal.	1. Check the wiring. 2. Ask for support.
TE	Autotuning fault	1. Improper setting of motor rated parameters. 2. Overtime of autotuning.	1. Set rated parameters according to motor nameplate. 2. Check motor's wiring.
PCE	Encoder fault	1. Signal wire of encoder was broken. 2. Encoder was damaged.	1. Inspect encoder connection. 2. Inspect whether the encoder output signal or not.
PCDE	Encoder reverse fault	Encoder signal wire was connected wrong.	Adjust encoder wiring.
OPSE	System fault	1. Serious disturbance cause control board unable to operate properly. 2. Noise cause control board malfunction.	1. Press STOP/RST to reset or install input filter at input side. 2. Ask for support.
EEP	EEPROM fault	Read/Write fault of control parameters	Press STOP/RESET to reset Ask for support
PPCE	Detection fault of magnetic pole	Fault of synchronous motor	1. Inspect motor parameters. 2. Input correct parameters of motor and re-autotuning.
BCE	Brake unit fault	1. Braking circuit failure or brake tube damaged. 2. Too low resistance of externally connected braking resistor.	1. Inspect braking unit, replace braking tube. 2. Increase braking resistance.
-END-	Trial time reached	Trial time which determined by factory reached.	Contact supplier and ask for support.
LCD-E	LCD disconnected	1. LCD disconnected 2. Material broken during tension control	1. Press STOP/RST to reset, connect LCD then download or upload parameter. 2. Check material.
FAE	Holding brake fault	Fault of brake feedback	Check the elevator control system.
TBE	Contactor feedback fault	Contactor feedback fault	Check the elevator control system.

9.2 Common Faults and Solutions

Inverter may have following faults or malfunctions during operation, please refer to the following solutions.

No display after power on:

- Inspect whether the voltage of power supply is the same as the inverter rated voltage or not with multi-meter. If the power supply has problem, inspect and solve it.
- Inspect whether the three-phase rectify bridge is in good condition or not. If the rectification bridge is burst out, ask for support.
- Check the CHARGE light. If the light is off, the fault is mainly in the rectify bridge or the buffer resistor. If the light is on, the fault may be lies in the switching power supply. Please ask for support.

Power supply air switch trips off when power on:

- Inspect whether the input power supply is grounded or short circuit. Please solve the problem.
- Inspect whether the rectify bridge has been burnt or not. If it is damaged, ask for support.

Motor doesn't move after inverter running:

- Inspect if there is balanced three-phase output among U, V, W. If yes, then motor could be damaged, or mechanically locked. Please solve it.
- If the output is unbalanced or lost, the inverter drive board or the output module may be damaged, ask for support..

Inverter displays normally when power on, but switch at the input side trips when running:

- Inspect whether the output side of inverter is short circuit. If yes, ask for support.
- Inspect whether ground fault exists. If yes, solve it.
- If trip happens occasionally and the distance between motor and inverter is too far, it is recommended to install output AC reactor.

10. MAINTENANCE



WARNING

- Maintenance must be performed according to designated maintenance methods.
- Maintenance, inspection and replacement of parts must be performed only by authorized personnel.
- After turning off the main circuit power supply, waiting for 10 minutes before performance maintenance or inspection.
- DO NOT directly touch components or devices of PCB board. Otherwise inverter can be damaged by electrostatic.
- After maintenance, all screws must be tightened.

10.1 Daily Maintenance

In order to prevent the fault of inverter to make it operate smoothly in high-performance for a long time, user must inspect the inverter periodically (within half year). The following table indicates the inspection content.

Items to be checked	Main inspections		Criteria
	Inspection content	Frequency	Means/methods
Operation environment	(1) temperature, humidity (2)dust, vapor, leakage (3)gases	(1)point thermometer, hygrometer (2)observation (3)visual examination and smelling	(1)ambient temperature shall be lower than 40°C, otherwise, the rated values should be decreased. Humidity shall meet the requirement (2)no dust accumulation, no traces of water leakage and no condensate. (3)no abnormal color and smell.

Items to be checked	Main inspections		Criteria
	Inspection content	Frequency	Means/methods
Inverter	(1)vibration (2)cooling and heating (3)noise	(1)point thermometer comprehensive observation (2)listening	(1)smooth operation without vibration. (2)fan is working in good condition. Speed and air flow are normal. No abnormal heat. (3)No abnormal noise
Motor	(1)vibration (2)heat (3)noise	(1)comprehensive observation Listening (2)point thermometer (3)listening	(1)No abnormal vibration and no abnormal noise. (2)No abnormal heat. (3)No abnormal noise.
Operation status parameters	(1)power input voltage (2)inverter output voltage (3)inverter output current (4)internal temperature	(1)voltmeter (2)rectifying voltmeter (3)ammeter (4)point thermometer	(1)satisfying the specification (2)satisfying the specification (3)satisfying the specification (4)temperature rise is lower than 40℃

10.2 Periodic Maintenance

Customer should check the drive every 3 months or 6 months according to the actual environment

1. Check whether the screws of control terminals are loose. If so, tighten them with a screwdriver;
2. Check whether the main circuit terminals are properly connected; whether the mains cables are over heated;
3. Check whether the power cables and control cables are damaged, check especially for any wear on the cable tube;
4. Check whether the insulating tapes around the cable lugs are stripped;
5. Clean the dust on PCBs and air ducts with a vacuum cleaner;
6. For drives that have been stored for a long time, it must be powered on every 2 years. When supplying AC power to the drive, use a voltage regulator to raise the input voltage to rated input voltage gradually. The drive should be powered for 5 hours without load.
7. Before performing insulation tests, all main circuit input/output terminals should be short-circuited with conductors. Then proceed insulation test to the ground. Insulation test of single main circuit terminal to ground is forbidden; otherwise the drive might be damaged. Please use a 500V Mega-Ohm-Meter.
8. Before the insulation test of the motor, disconnect the motor from the drive to avoid damaging it.

10.3 Replacement of wearing parts

Fans and electrolytic capacitors are wearing part, please make periodic replacement to ensure long term, safety and failure-free operation. The replacement periods are as follows:

- ◆Fan: Must be replaced when using up to 20,000 hours;
- ◆Electrolytic Capacitor: Must be replaced when using up to 30,000~40,000 hours.

11. COMMUNICATION PROTOCOL

11.1 Interfaces

RS485: asynchronous, half-duplex.

Default: 8-E-1, 19200bps. See Group PC parameter settings.

11.2 Communication Modes

- (1) The protocol is Modbus protocol. Besides the common register Read/Write operation, it is supplemented with commands of parameters management.
- (2) The drive is a slave in the network. It communicates in 'point to point' master-slave mode. It will not respond to the command sent by the master via broadcast address.
- (3) In the case of multi-drive communication or long-distance transmission, connecting a 100~120Ω resistor in parallel with the master signal line will help to enhance the immunity to interference.

11.3 Protocol Format

Modbus protocol supports both RTU and ASCII mode. The frame format is illustrated as follows:

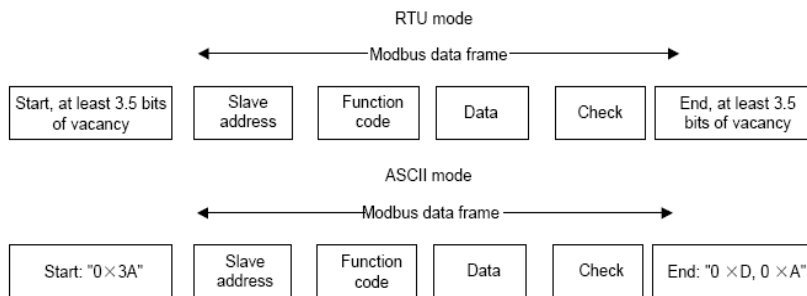

Modbus adopts "Big Endian" representation for data frame. This means that when a numerical quantity larger than a byte is transmitted, the most significant byte is sent first.

RTU mode

In RTU mode, the Modbus minimum idle time between frames should be no less than 3.5 bytes. The checksum adopts CRC-16 method. All data except checksum itself sent will be counted into the calculation. Please refer to section: CRC Check for more information. Note that at least 3.5 bytes of Modbus idle time should be kept and the start and end idle time need not be summed up to it.

The table below shows the data frame of reading parameter 002 from slave node address 1.

Node addr.	Command	Data addr.		Read No.		CRC	
0x01	0x03	0x00	0x02	0x00	0x01	0x25	0xCA

The table below shows the reply frame from slave node address 1

Node addr.	Command	Bytes No.	Data		CRC	
0x01	0x03	0x02	0x00	0x00	0xB8	0x44

ASCII mode

In ASCII mode, the frame head is "0x3A", and default frame tail is "0x0D" or "0x0A". The frame tail can also be configured by users. Except frame head and tail, other bytes will be sent as two ASCII characters, first sending higher nibble and then lower nibble. The data have 7/8 bits. "A"~"F" corresponds to the ASCII code of respective capital letter. LRC check is used. LRC is calculated by adding all the successive bytes of the message except the head and tail, discarding any carriers, and then two's complementing the result.

Example of Modbus data frame in ASCII mode:

The command frame of writing 0x0003 into address "0x1000" of slave node address 1 is shown in the table below:

LRC checksum = the complement of (01+06+10+00+0x00+0x03) = 0xE5

	Frame head		Node addr.		Command		Data addr.			
Code			0	1	0	6	1	0	0	0
ASCII	3A		30	31	30	36	31	30	30	30
Data to write				LRC		Frame tail				
0	0	0	3	E	5	CR		LF		
30	30	30	33	45	35	0D		0A		

11.4 Protocol function

Different respond delay can be set through drive's parameters to adapt to different needs. For RTU mode, the respond delay should be no less than 3.5 bytes interval, and for ASCII mode, no less than 1ms.

The main function of Modbus is to read and write parameters. The Modbus protocol supports the following commands:

0x03	Read inverter's function parameter and status parameters
0x06	Write single function parameter or command parameter to inverter

All drive's function parameters, control and status parameters are mapped to Modbus R/W data address.

The data addresses of each function parameters please refer the sixth column of chapter 9.

The data address of control and status parameters please refer to the following table.

Parameter Description	Address	Meaning of value	R/W Feature
Control command	1000H	0001H: Forward	W/R
		0002H: Reverse	
		0003H: JOG forward	
		0004H: JOG reverse	
		0005H: Stop	
		0006H: Coast to stop	
		0007H: Reset fault	
		0008H: JOG stop	
Inverter status	1001H	0001H: Forward running	R
		0002H: Reverse running	
		0003H: Standby	
		0004H: Fault	
Communication setting	2000H	Communication Setting Range (-10000~10000) Note: the communication setting is the percentage of the relative value (-100.00%~100.00%). If it is set as frequency source, the value is the percentage of the maximum frequency (P0.04). If it is set as PID (preset value or feedback value), the value is the percentage of the PID.	W/R
Virtual terminal input function setting	2001H	Setting range: 000H~03FFH. Each bit corresponds to S1~S5, HDI1, HDI2 and S6~S8 respectively. Notice: The functional code P5.01 should be set to the communication virtual terminal input function, and should also be unrelated to HDI1 and HDI2 input types.	W/R
Status parameters	3000H	Output speed	R
	3001H	Reference speed	R
	3002H	DC Bus voltage	R
	3003H	Output voltage	R
	3004H	Output current	R
	3005H	Running frequency	R
	3006H	Rotation speed	R
	3007H	Output power	R
	3008H	Output torque	R
	3009H	Input terminal status	R
	300AH	Output terminal status.	R

Communication Protocol

	300BH	Input of AI1	R
	300CH	Input of AI2	R
	300DH	Torque compensation	R
	300EH	Pole position	R
	300FH ~ 3014H	Reserved	R
	3015H	Torque direction (0: forward, 1: reverse)	R
	3016H	Device code	R
Parameter lock password check address	4000H	****	R
Parameter lock password command address	4001H	55AAH	R
Fault info address	5000H	This address stores the fault type of inverter. The meaning of each value is same as P7.15.	R

The above shows the format of the frame. Now we will introduce the Modbus command and data structure in details, which is called protocol data unit for simplicity. Also MSB stands for the most significant byte and LSB stands for the least significant byte for the same reason. The description below is data format in RTU mode. The length of data unit in ASCII mode should be doubled.

Protocol data unit format of reading parameters:

Request format:

Protocol data unit	Data length(bytes)	Range
Command	1	0x03
Data Address	2	0~0xFFFF
Read number	2	0x0001~0x0010

Reply format (success):

Protocol data unit	Data length(bytes)	Range
Command	1	0x03
Returned byte number	2	2* Read number
Content	2* Read number	

If the command is reading the type of inverter (data address 0x3016), the content value

in reply message is the device code:

The high 8 bit of device code is the type of the inverter, and the low 8 bit of device code is the sub type of inverter.

For details, please refer to the following table:

High byte	Meaning	Low byte	Meaning
00	CHV	01	Universal type
		02	For water supply
		03	Middle frequency 1500HZ
		04	Middle frequency 3000HZ
01	CHE	01	Universal type
		02	Middle frequency 1500HZ
02	CHF	01	Universal type

If the operation fails, the inverter will reply a message formed by failure command and error code. The failure command is (Command+0x80). The error code indicates the reason of the error; see the table below.

Value	Name	Mean
01H	Illegal command	The command from master can not be executed. The reason maybe: 1. This command is only for new version and this version can not realize. 2. Slave is in fault status and can not execute it.
02H	Illegal data address.	Some of the operation addresses are invalid or not allowed to access.
03H	Illegal value	When there are invalid data in the message framed received by slave. Note: This error code does not indicate the data value to write exceed the range, but indicate the message frame is a illegal frame.
06H	Slave busy	Inverter is busy(EEPROM is storing)
10H	Password error	The password written to the password check address is not same as the password set by P7.00.
11H	Check error	The CRC (RTU mode) or LRC (ASCII mode) check not passed.
12H	Written not allowed.	It only happen in write command, the reason maybe: 1. the data to write exceed the range of according parameter 2. The parameter should not be modified now. 3. The terminal has already been used.

13H	System locked	When password protection take effect and user does not unlock it, write/read the function parameter will return this error.
-----	---------------	---

Protocol data unit format of writing single parameter:

Request format:

Protocol data unit	Data length(bytes)	Range
Command	1	0x06
Data Address	2	0~0xFFFF
Write Content	2	0~0xFFFF

Reply format (success):

Protocol data unit	Data length(bytes)	Range
Command	1	0x06
Data Address	2	0~0xFFFF
Write Content	2	0~0xFFFF

If the operation fails, the inverter will reply a message formed by failure command and error code. The failure command is (Command+0x80). The error code indicates the reason of the error; see table 1.

11.5 Note:

10.5.1 Between frames, the span should not less than 3.5 bytes interval, otherwise, the message will be discarded.

10.5.2 Be cautious to modify the parameters of PC group through communication, otherwise may cause the communication interrupted.

10.5.3 In the same frame, if the span between two .near bytes more than 1.5 bytes interval, the behind bytes will be assumed as the start of next message so that communication will failure.

11.6 CRC Check

For higher speed, CRC-16 uses tables. The following are C language source code for CRC-16.

```

unsigned int crc_cal_value(unsigned char *data_value,unsigned char data_length)
{
int i;
unsigned int crc_value=0xffff;
while(data_length--)
{
crc_value^=*data_value++;
for(i=0;i<8;i++)
{
if(crc_value&0x0001)crc_value=(crc_value>>1)^0xa001;
else crc_value=crc_value>>1;
}
}
}
    
```

```

}
return(crc_value);
}

```

11.7 Example

11.7.1 RTU mode, read 2 data from 0004H

The request command is:

START	T1-T2-T3-T4 (transmission time of 3.5 bytes)
Node address	01H
Command	03H
High byte of start address	00H
Low byte of start address	04H
High byte of data number	00H
Low byte of data number	02H
Low byte of CRC	85H
High byte of CRC	CAH
END	T1-T2-T3-T4 (transmission time of 3.5 bytes)

The reply is :

START	T1-T2-T3-T4 (transmission time of 3.5 bytes)
Node address	01H
Command	03H
Returned byte number	04H
Higher byte of 0004H	13H
Low byte of 0004H	88H
High byte of 0005H	05H
Low byte of 0005H	DCH

Low byte of CRC	7CH
High byte of CRC	54H
END	T1-T2-T3-T4 (transmission time of 3.5 bytes)

11.7.2 ASCII mode, read 2 data from 0004H:

The request command is:

START	‘:’
Node address	‘0’
	‘1’
Command	‘0’
	‘3’
High byte of start address	‘0’
	‘0’
Low byte of start address	‘0’
	‘4’
High byte of data number	‘0’
	‘0’
Low byte of data number	‘0’
	‘2’
LRC CHK Hi	‘F’
LRC CHK Lo	‘6’
END Lo	CR
END Hi	LF

The reply is

START	‘:’
Node address	‘0’
	‘1’
Command	‘0’
	‘3’
Returned byte number	‘0’
	‘4’
Higher byte of 0004H	‘1’
	‘3’
Low byte of 0004H	‘8’
	‘8’
High byte of 0005H	‘0’
	‘5’
Low byte of 0005H	‘D’

	'C'
LRC CHK Lo	'7'
LRC CHK Hi	'C'
END Lo	CR
END Hi	LF

11.7.3 RTU mode, write 5000(1388H) into address 0008H, slave node address 02.

The request command is:

START	T1-T2-T3-T4 (transmission time of 3.5 bytes)
Node address	02H
Command	06H
High byte of data address	00H
Low byte of data address	04H
High byte of write content	13H
Low byte of write content	88H
Low byte of CRC	C5H
High byte of CRC	6EH
END	T1-T2-T3-T4 (transmission time of 3.5 bytes)

The reply command is:

START	T1-T2-T3-T4 (transmission time of 3.5 bytes)
Node address	02H
Command	06H
High byte of data address	00H
Low byte of data address	04H
High byte of write content	13H
Low byte of write content	88H

Low byte of CRC	C5H
High byte of CRC	6EH
END	T1-T2-T3-T4 (transmission time of 3.5 bytes)

11.7.4 ASCII mode, write 5000(1388H) into address 0008H, slave node address 02.

The request command is:

START	‘:’
Node address	‘0’
	‘2’
Command	‘0’
	‘6’
High byte of data address	‘0’
	‘0’
Low byte of data address	‘0’
	‘4’
High byte of write content	‘1’
	‘3’
Low byte of write content	‘8’
	‘8’
LRC CHK Hi	‘5’
LRC CHK Lo	‘9’
END Lo	CR
END Hi	LF

The reply command is:

START	‘:’
Node address	‘0’
	‘2’
Command	‘0’
	‘6’
High byte of data address	‘0’
	‘0’
Low byte of data address	‘0’
	‘4’
High byte of write content	‘1’
	‘3’
Low byte of write content	‘8’

	'8'
LRC CHK Hi	'5'
LRC CHK Lo	'9'
END Lo	CR
END Hi	LF

12. LIST OF FUNCTION PARAMETERS

Notice:

1. PE group is factory reserved, users are forbidden to access these parameters.
2. The column "Modify" determines the parameter can be modified or not.
 - "○" indicates that this parameter can be modified all the time.
 - "◎" indicates that this parameter cannot be modified during the inverter is running.
 - "●" indicates that this parameter is read only.
3. "Factory Setting" indicates the value of each parameter while restoring the factory parameters, but those detected parameters or record values cannot be restored.

Function Code	Name	Description	Factory Setting	Modify	LCD Display
P0 Group: Basic Function					
P0.00	Speed control mode	0:Sensorless vector control 1:Vector control With PG 2:V/F control	1	◎	CONTROL MODE
P0.01	Run command source	0: Keypad 1: Terminal 2: Communication	1	◎	RUN COMMAND
P0.02	Elevator rating speed	0.100~4.00m/s	1.500m/s	◎	RATING SPEED
P0.03	Speed command source	0: Keypad 1: AI1 2: AI2 3: Multi-Step speed 4: Communication 5: Reserved	3	◎	SPEED SOURCE
P0.04	Maximum frequency	10.0~400.00Hz	50.00Hz	◎	MAX FREQ
P0.05	Keypad reference speed	0.00 Hz ~ P0.02	1.500m/s	○	KEYPAD REF SPEED
P0.06	Running direction selection	0: Forward 1: Reverse 2: Forbid reverse	0	◎	RUN DIRECTION

List of Function parameters

Function Code	Name	Description	Factory Setting	Modify	LCD Display
P0.07	Carrier frequency	1.0~16.0kHz	Depend on model	○	CARRIER FREQ
P0.08	Motor parameters autotuning	0: No action 1: Rotation autotuning 2: Static autotuning	0	◎	AUTOTUNING
P0.09	Restore parameters	0: No action 1: Restore factory setting 2: Clear fault records 3: Restore parameters for injection molding machine	0	◎	RESTORE PARA
P0.10 ~P0.11	Reserve function	0~65536	0	◎	RESERVE FUNCTION
P1 Group: Speed curve					
P1.00	Multi-step speed 0	0.000~P0.02	0.000m/s	○	MULTI-STEP SPEED 0
P1.01	Multi-step speed 1	0.000~P0.02	0.000m/s	◎	MULTI-STEP SPEED 1
P1.02	Multi-step speed 2	0.000~P0.02	0.000m/s	◎	MULTI-STEP SPEED 2
P1.03	Multi-step speed 3	0.000~P0.02	0.000m/s	◎	MULTI-STEP SPEED 3
P1.04	Multi-step speed 4	0.000~P0.02	0.000m/s	◎	MULTI-STEP SPEED 4
P1.05	Multi-step speed 5	0.000~P0.02	0.000m/s	◎	MULTI-STEP SPEED 5
P1.06	Multi-step speed 6	0.000~P0.02	0.000m/s	◎	MULTI-STEP SPEED 6
P1.07	Multi-step speed 7	0.000~P0.02	0.000m/s	◎	MULTI-STEP SPEED 7
P1.08	Start quadric acceleration	0.001~10.000 m/s ³	0.350m/s ³	◎	START QUADRIC ACCEL
P1.09	Start acceleration	0.001~10.000 m/s ²	0.700m/s ²	◎	START ACCEL
P1.10	Speed-down quadric deceleration	0.001~10.000 m/s ³	0.350m/s ³	◎	SPEED-DOWN QUADRIC DECEL
P1.11	Deceleration	0.001~10.000 m/s ²	0.700m/s ²	◎	DECEL
P1.12	Stop quadric deceleration	0.001~10.000 m/s ³	0.350m/s ³	◎	STOP QUADRIC DECEL

List of Function Parameters

Function Code	Name	Description	Factory Setting	Modify	LCD Display
P1.13	Stop deceleration	0.001 ~ 10.000 m/s ²	0.700m/s ²	☉	STOP DECEL
P1.14	Start speed	0.000 ~ 0.250 m/s ²	0.000m/s	☉	START SPEED
P1.15	Start holding time	0.0 ~ 5.0s	0.0s	☉	START HOLDING
P1.16	Overhaul running speed	0.000 m/s ~ P0.02	0.300m/s	☉	OVERHAUL RUNNING TIME
P1.17	Overhaul running acceleration	0.001 ~ 10.000 m/s ²	1.000m/s ²	☉	OVERHAUL RUNNING ACCEL
P1.18	Overhaul running deceleration	0.001 ~ 10.000 m/s ²	1.000m/s ²	☉	OVERHAUL RUNNING DECEL
P1.19	Motor autotuning acceleration	0.001 ~ 10.000 m/s ²	0.600 m/s ²	☉	MOTOR AUTOTUNING ACCEL
P1.20	Motor autotuning deceleration	0.001 ~ 10.000 m/s ²	0.600m/s ²	☉	MOTOR AUTOTUNING DECEL
P1.21	Emergence running acceleration	0.000 ~ P0.02 m/s	0.300m/s	☉	EMERGENCE RUNNING ACCEL
P1.22	Emergence running deceleration	0.001 ~ 10.000 m/s ²	1.000m/s ²	☉	EMERGENCE RUNNING DECEL
P1.23	Forcing slow-down deceleration 1	P1.25 ~ 10.000 m/s ²	1.000m/s ²	☉	FORCING SLOW-DOWN DECEL 1
P1.24	Forcing slow-down speed 1 check	0.0 ~ P1.26	20.0%	☉	FORCING SLOW-DOWN SPEED 1 CHECK
P1.25	Forcing slow-down deceleration 2	P1.27 ~ P1.23 m/s ²	0.900m/s ²	☉	FORCING SLOW-DOWN DECEL 2

List of Function parameters

Function Code	Name	Description	Factory Setting	Modify	LCD Display
P1.26	Forcing slow-down speed 2 check	P1.24~P1.28	40.0%	⊙	FORCING SLOW-DOWN SPEED 2 CHECK
P1.27	Forcing slow-down deceleration 3	0.001~P1.25 m/s ²	0.700m/s ²	⊙	FORCING SLOW-DOWN DECEL 3
P1.28	Forcing slow-down speed 3 check	P1.26~100.0%	80.0%	⊙	FORCING SLOW-DOWN SPEED 3 CHECK
P1.29	Stop mode selection	0~1	1	⊙	STOP MODE
P1.30~P1.30	Reserve function	0~65535	0	⊙	RESERVE FUNCTION
P2 Group: Motor Parameters					
P2.00	Inverter model	0: asynchronous motor 1: synchronous motor	0	⊙	INVERTER MODEL
P2.01	Traction motor wheel diameter	100~2000mm	500mm	⊙	TRACTION MOTOR WHEEL DIA
P2.02	Speed-down rate	1.00~100.00	30.00	⊙	SPEED-DOWN RATE
P2.03	Tow hanging rate	1~8	1	⊙	TOW HANGING RATE
P2.04	Motor rated power	0.4~900.0kW	Depend on model	⊙	MOTOR RATE POWER
P2.05	Motor rated frequency	0.01Hz~P0.04	50.00Hz	⊙	MOTOR RATE FREQ
P2.06	Motor rated speed	0~36000rpm	1460 rpm	⊙	MOTOR RATE SPEED
P2.07	Motor rated voltage	0~3000V	380V	⊙	MOTOR RATE VOLT

List of Function Parameters

Function Code	Name	Description	Factory Setting	Modify	LCD Display
P2.08	Motor rated current	0.1~2000.0A	Depend on model	☉	MOTOR RATE CURR
P2.09	Motor rating power factor	0.05~1.00	0.86	☉	MOTOR RATE POWER FACTOR
P2.10	Motor stator resistance	0.001~65.535Ω	Depend on model	○	STATOR RESISTOR
P2.11	Motor rotor resistance	0.001~65.535Ω	Depend on model	○	ROTOR RESISTOR
P2.12	Motor leakage inductance	0.1~6553.5mH	Depend on model	○	LEAK INDUCTOR
P2.13	Motor mutual inductance	0.1~6553.5mH	Depend on model	○	MUTUAL INDUCTOR
P2.14	Current without load	0.01~655.35A	Depend on model	○	NO LOAD CURR
P2.15~ P2.16	Reserve function	0~65535	0	☉	RESERVE FUNCTION
P3 Group: Vector Control					
P3.00	ASR proportional gain K_p1	0~100	20	○	ASR K_p1
P3.01	ASR integral time K_i1	0.01~10.00s	0.50s	○	ASR K_i1
P3.02	Speed inspect low speed filter time	0.000 ~ 1.000s	0.000s	○	SPEED INSPECT FILTER T1
P3.03	ASR switching point 1	0.00Hz~P3.07	5.00Hz	○	ASR SWITCHPOIN T1
P3.04	ASR proportional gain K_p2	0~100	25	○	ASR K_p2
P3.05	ASR integral time K_i2	0.01~10.00s	1.00s	○	ASR K_i2

List of Function parameters

Function Code	Name	Description	Factory Setting	Modify	LCD Display
P3.06	Speed inspect high speed filter time	0.000~1.000s	0.000s	○	SPEED INSPECT FILTER T1
P3.07	ASR switching point 2	P3.03~P0.04	10.00Hz	○	ASR SWITCHPOIN T2
P3.08	ACR proportional gain P	0~65535	500	○	ACR P
P3.09	ACR integral gain I	0~65535	500	○	ACR I
P3.10	Slip compensation rate of drive side	50.0~200.0%	100%	○	DRIVE SLIP COMP
P3.11	Slip compensation rate of trig side	50.0~200.0%	100%	○	TRIG SLIP COMP
P3.12	Torque limit	0.0~200.0%(rated current of inverter)	150.0%	○	TORQUE LIMIT
P3.13~P3.14	Reserve function	0~65535	0	◎	RESERVE FUNCTION
P4 Group: Encoder parameter					
P4.00	Encoder type selection	0: Increment encoder 1: SIN/COS encoder 2: UVM encoder	0	◎	ENCODE TYPR
P4.01	PG parameter	1~65536	1000	◎	TORQUE BOOST
P4.02	PG direction selection	1: forward 2: reverse	0	◎	BOOST CUT-OFF
P4.03	Pole initial position	0.00~360.00	0.00	◎	POLE INITIAL POSITION
P4.04	Thread break detection time of encoder low speed	0.0~100.0s	1.0	◎	THREAD BREAK DETECTION T1
P4.05	Thread break detection time of encoder high speed	0.0~100.0s	1.0	◎	THREAD BREAK DETECTION T2

List of Function Parameters

Function Code	Name	Description	Factory Setting	Modify	LCD Display
P4.06	Reverse detection time of encoder	0.0~100.0s	1.0	☉	REVERSE DETECTION TIME
P4.07	Pole position amplitude plus	0.50~1.50	1.00	☉	POLE POSITION AMP PLUS
P4.08	C phase pole position offset	0~999	385	☉	C POLE POSITION OFFSET
P4.09	D phase pole position offset	0~999	385	☉	D POLE POSITION OFFSET
P4.10~P4.11	Reserve function	0~65535	0	☉	RESERVE FUNCTION
P5 Group: Input Terminals					
P5.00	Terminal input mode selection	0~0x3FF	0	☉	INPUT MODE
P5.01	Input selection	0: Concrete 1: Virtual	0	☉	INPUT SELECTION
P5.02	S1 Terminal function	0:Invalid 1: Up running 2: Down running 3: Examine running 4: Emergency running 5: Free stop 6: Fault reset 7: Exterior fault input 8~10: Multi-speed terminals 1~3 11~13: Uplink forcing deceleration 1~3 14~16: Downlink forcing deceleration 1~3 17: Contactor feedback signal 18: Brake feedback signal 19: Inverter enable 20~40: reversed	1	☉	S1 FUNCTION
P5.03	S2 Terminal function		2	☉	S2 FUNCTION
P5.04	S3 Terminal function		8	☉	S3 FUNCTION
P5.05	S4 Terminal function		9	☉	S4 FUNCTION
P5.06	S5 Terminal function		3	☉	S5 FUNCTION
P5.07	S6 Terminal function		0	☉	S6 FUNCTION
P5.08	S7 Terminal function		0	☉	S7 FUNCTION
P5.09	S8 Terminal function		0	☉	S8 FUNCTION
P5.10	S9 Terminal function		0	☉	S9 FUNCTION
P5.11	S10 Terminal function		0	☉	S10 FUNCTION

List of Function parameters

Function Code	Name	Description	Factory Setting	Modify	LCD Display
P5.12	ON-OFF filter times	1~10	5	○	Sx FILTER TIMES
P5.13	AI1 lower limit	0.00V~10.00V	0.00V	○	AI1 LOW LIMIT
P5.14	AI1 lower limit corresponding setting	-100.0%~100.0%	0.0%	○	AI1 LOW SETTING
P5.15	AI1 upper limit	0.00V~10.00V	10.00V	○	AI1 UP LIMIT
P5.16	AI1 upper limit corresponding setting	-100.0%~100.0%	100.0%	○	AI1 UP SETTING
P5.17	AI1 filter time constant	0.00s~10.00s	0.10s	○	AI1 FILTER TIME
P5.18	AI2 lower limit	0.00V~10.00V	0.00V	○	AI2 LOW LIMIT
P5.19	AI2 lower limit corresponding setting	-100.0%~100.0%	0.0%	○	AI2 LOW SETTING
P5.20	AI2 upper limit	0.00V~10.00V	5.00V	○	AI2 UP LIMIT
P5.21	AI2 upper limit corresponding setting	-100.0%~100.0%	100.0%	○	AI2 UP SETTING
P5.22	AI2 filter time constant	0.00s~10.00s	0.10s	○	AI2 FILTER TIME
P5.23~ P5.24	Reserve function	0~65535	0	◎	RESERVE FUNCTION
P6 Group: Output Terminals					
P6.00	HDO selection	0: High-speed pulse output 1: ON-OFF output	0	◎	HDO SELECTION
P6.01	Y1 output selection	0: NO output 1: Elevator running	1	○	Y1 SELECTION
P6.02	Y2 output selection	2: Up running 3: Down running	0	○	Y2 SELECTION
P6.03	HDO ON-OFF output selection	4: Fault output 5: Zero speed running	0	○	HDO SELECTION
P6.04	Relay 1 output selection	6: Ready 7: Brake control	4	○	RO1 SELECTION

List of Function Parameters

Function Code	Name	Description	Factory Setting	Modify	LCD Display
P6.05	Relay 2 output selection	8: Contactor control 9: Frequency reached	5	○	RO2 SELECTION
P6.06	Relay 3 output selection	10: FDT reached 11~20: Reserved	0	○	RO3 SELECTION
P6.07	AO1 function selection	0: Running speed 1: Reference speed 2: Motor speed 3: Output current	0	○	AO1 SELECTION
P6.08	AO2 function selection	4: Output voltage 5: Output power 6: Output torque 7: AI1 voltage	1	○	AO2 SELECTION
P6.09	HDO function selection	8: AI2 voltage/current 9~14: Reserved	0	○	HDO SELECTION
P6.10	AO1 lower limit	0.0%~100.0%	0.0%	○	AO1 LOW LIMIT
P6.11	AO1 lower limit corresponding output	0.00V ~10.00V	0.00V	○	AO1 LOW OUTPUT
P6.12	AO1 upper limit	0.0%~100.0%	100.0%	○	AO1 UP LIMIT
P6.13	AO1 upper limit corresponding output	0.00V ~10.00V	10.00V	○	AO1 UP OUTPUT
P6.14	AO2 lower limit	0.0%~100.0%	0.0%	○	AO2 LOW LIMIT
P6.15	AO2 lower limit corresponding output	0.00V ~10.00V	0.00V	○	AO2 LOW OUTPUT
P6.16	AO2 upper limit	0.0%~100.0%	100.0%	○	AO2 UP LIMIT
P6.17	AO2 upper limit corresponding output	0.00V ~10.00V	10.00V	○	AO2 UP OUTPUT
P6.18	HDO lower limit	0.0%~100.0%	0.0%	○	HDO LOW LIMIT
P6.19	HDO lower limit corresponding output	0.0 ~ 50.0kHz	0.0kHz	○	HDO LOW OUTPUT
P6.20	HDO upper limit	0.0%~100.0%	100.0%	○	HDO UP LIMIT

List of Function parameters

Function Code	Name	Description	Factory Setting	Modify	LCD Display
P6.21	HDO upper limit corresponding output	0.0 ~ 50.0kHz	50.0kHz	○	HDO UP OUTPUT
P6.22	FDT level	0.00~P0.07	50.00Hz	○	FDT LEVEL
P6.23	FDT lag	0.0~100.0	5.0%	○	FDT LAG
P6.24	Frequency arrive detecting range	0.00~100.0%	0.0%	○	FREQ ARRIVE DETECT
P6.25~ P6.26	Reserve function	0~65535	0	◎	RESERVE FUNCTION
P7 Group: Display Interface					
P7.00	User password	0~65535	0	○	USER PASSWORD
P7.01	LCD language selection	0: Chinese 1: English	0	○	LANGUAGE SELECT
P7.02	Parameter copy	0: Invalid 1: Upload parameters to LCD 2: Download parameters from LCD	0	◎	PARA COPY
P7.03	QUICK/JOG function selection	0: Quick debugging mode 1: FDW/REV switching 2: Jog 3: Clear UP/DOWN setting	0	◎	QUICK/JOG FUNC
P7.04	STOP/RST function selection	0: Valid when keypad control (P0.01=0) 1: Valid when keypad or terminal control (P0.01=0 or 1) 2: Valid when keypad or communication control (P0.01=0 or 2) 3: Always valid	0	○	STOP/RST FUNC
P7.05	Keypad display selection	0: Preferential to external keypad 1: Both display, only external key valid. 2: Both display, only local key valid. 3: Both display and key valid.	0	○	KEYPAD DISPLAY

List of Function Parameters

Function Code	Name	Description	Factory Setting	Modify	LCD Display
P7.06	Running status display selection	1.Output speed 2.Reference speed 3.DC bus voltage 4.Output voltage 5.Output current Other parameters display is determined by 16 bit binary digit BIT0: Running frequency BIT1: Rotation speed BIT2: Output power BIT3: Output torque BIT4: Input terminal status BIT5: Output terminal status BIT6: AI1 BIT7: AI2 BIT8: Torque compensation BIT9: Pole position BIT10~ BIT15: Reserved	0x00FF	○	RUNNING DISPLAY
P7.07	Stop status display selection	BIT0: Running speed BIT1: Reference speed BIT2: DC bus voltage BIT3: Input terminal status BIT4: Output terminal status BIT5: Motor poles BIT6: AI1 BIT7: AI2 BIT8: Pole position BIT9: ~BIT15: Reserved	0x00FF	○	STOP DISPLAY
P7.08	Rectifier module temperature	0~100.0°C		●	RECTIFIER TEMP
P7.09	IGBT module temperature	0~100.0°C		●	IGBT TEMP
P7.10	MCU software version	Factory setting		●	MCU VERSION

Function Code	Name	Description	Factory Setting	Modify	LCD Display
P7.11	DSP software version	Factory setting		•	DSP VERSION
P7.12	Accumulated running time	0~65535h		•	TOTAL RUN TIME
P7.13	Third latest fault type	0: Not fault 1: IGBT Ph-U fault(OUT1) 2: IGBT Ph-V fault(OUT2) 3: IGBT Ph-W fault(OUT3) 4: Over-current when acceleration(OC1) 5: Over-current when deceleration(OC2) 6: Over-current when constant speed running (OC3) 7: Over-voltage when acceleration(OV1)		•	3rd LATEST FAULT
P7.14	Second latest fault type	8: Over-voltage whe deceleration(OV2) 9: Over-voltage when constant speed running(OV3) 10: DC bus Under-voltage(UV) 11: Motor overload (OL1) 12: Inverter overload (OL2) 13: Input phase failure (SPI) 14: Output phase failure (SPO) 15: Rectify overheat (OH1) 16: IGBT overheat (OH2) 17: External fault (EF) 18: Communication fault (CE) 19: Current detection fault (ITE) 20: Autotuning fault (TE) 21: Encoder fault(PCE) 22: Encoder reverse fault(PCDE) 23: System fault(OPSE) 24: EEPROM fault (EEP)		•	2nd LATEST FAULT
P7.15	Latest fault type	25: Pole position check fault (PPCE) 26: Brake unit fault (BCE) 27: Trial time reached(END) 28: LCD disconnected(LCD-E) 29: Brake action fault(FAE) 30: Contactor feedback(TbE)		•	CURRENT FAULT

List of Function Parameters

Function Code	Name	Description	Factory Setting	Modify	LCD Display
P7.16	Output frequency at current fault			•	FAULT FREQ
P7.17	Output current at current fault			•	FAULT CURR
P7.18	DC bus voltage at current fault			•	FAULT DC VOLT
P7.19	Input terminal status at current fault			•	FAULT Sx STATUS
P7.20	Output terminal status at current fault			•	FAULT DO STATUS
P7.21~ P7.22	Reserve function	0~65535	0	◎	RESERVE FUNCTION
P8 Group: Enhanced Function					
P8.00	Analog weigh signal input selection	0: No function 1: AI1 2: AI2	0	◎	ANALOG WEIGH INPUT
P8.01	Preparation torque offset	0.0~100.0%	30.0%	○	PREP TORQUE OFFSET
P8.02	Drive pluse	0.000~7.000	1.000	○	DRIVE PLUSE
P8.03	Brake pluse	0.000~7.000	1.000	○	BRAKE PLUSE
P8.04	Brake, contactor control selection	0: Invailble 1: Brake availble, contactor invailble 2: Brake invailble, contactor available 3: Brake and contactor available	0	◎	BRAKE CONTACTOR CONTROL
P8.05	Close brake delay time	0.00~5.00s	0	◎	CLOSE BRAKE DELAY

List of Function parameters

Function Code	Name	Description	Factory Setting	Modify	LCD Display
P8.06	Open brake delay time	0.00~5.00s	0	☉	OPEN BRAKE DELAY
P8.07	Brake threshold voltage	560.0~750.0V	700.0V	○	BRAKE THRE VOLT
P8.08	Auto reset times	0~3	0	○	AUTO RESET TIMES
P8.09	Fault relay action	0: Disabled 1: Enabled	0	○	FAULT ACTION
P8.10	Reset interval	0.1~100.0s	1.0s	○	RESET INTERVAL
P8.11	Brake feedback inspecting interval	0.1~5.0s	2.0	☉	BRAKE FEEDBACK INTERVAL
P8.12	Contactoer feedback inspecting interval	0.1~5.0s	2.0	☉	CONTACTOR FEEDBACK INTERVAL
P9 Group: Protection Function					
P9.00	Input phase-failure protection	0: Disabled 1: Enabled	1	○	IN PHASE FAIL
P9.01	Output phase-failure protection	0: Disabled 1: Enabled	1	○	OUT PHASE FAIL
P9.02	Motor overload protection	0: Disabled 1: Normal motor 2: Variable frequency motor	2	☉	MOTOR OVERLOAD
P9.03	Motor overload protection current	20.0%~120.0%	100.0%	○	OVERLOAD CURR
P9.04	Overload pre-warning threshold	20.0%~150.0%	130.0%	○	OL WARN CURR

List of Function Parameters

Function Code	Name	Description	Factory Setting	Modify	LCD Display
P9.05	Overload pre-warning selection	0: Always detect relative to motor rated current 1: Detect while constant speed relative to motor rated current 2: Always detect relative to inverter rated current 3: Detect while constant speed relative to inverter rated current	0	☉	OL WARN SELECT
P9.06	Overload pre-warning delay time	0.0~30.0s	5.0s	○	OL WARN DELAY
P9.07	Inverter stop delay time	0.00~5.00s	0.00s	☉	INVERTER STOP DELAY
P9.08	Reserve function	0~65535	0	☉	RESERVE FUNCTION
PA Group: Serial Communication					
PA.00	Local address	1~247 0: broadcast address	1	○	LOCAL ADDRESS
PA.01	Baud rate selection	0: 1200BPS 1: 2400BPS 2: 4800BPS 3: 9600BPS 4: 19200BPS 5: 38400BPS	4	○	BAUD RATE
PA.02	Data format	0: No parity (8,N,2) for RTU 1: Even parity (8,E,1) for RTU 2: Odd parity (8,O,1) for RTU 3: No parity (8,N,2) for ASCII 4: Even parity (8,E,1) for ASCII 5: Odd parity (8,O,1) for ASCII 6: No parity (7,N,2) for ASCII 7: Even parity (7,E,1) for ASCII 8: Odd parity (7,O,1) for ASCII	0	○	DATA FORMAT

List of Function parameters

Function Code	Name	Description	Factory Setting	Modify	LCD Display
PA.03	Communication delay time	0~20ms	0	○	COM DELAY TIME
PA.04	Communication timeout delay	0.0 (invalid) 0.1~100.0s	0.0s	○	COM TIMEOUT
PA.05	Response action	0: Enabled 1: Disabled	0	○	RESPONSE ACTION
PA.06~ PA.08	Reserve function	0~65535	0	◎	RESERVE FUNCTION
PB Group: Distance Control (Reserve)					
PE Group: Factory Setting					
PE.00	Factory Password	0~65535	*****	●	FACTORY PASSWORD