

---

# JPS

**JPS-PD SERIES IGBT PWM INVERTER**  
**INSTRUCTION MANUAL**

# CONTENTS

## 1 LOCAL PANEL

- 1.1 CTL MODE
- 1.2 MON MODE
- 1.3 PAR MODE
- 1.4 ALM MODE

## 2 REMOTE PANEL

- 2.1 CTL MODE
- 2.2 MON MODE
- 2.3 PAR MODE
- 2.4 JOG MODE
- 2.5 ALM MODE

## 3 PARAMETERS

- 3.1 PARAMETER LIST
- 3.2 PARAMETER PROTECTION
- 3.3 PARAMETER RELOAD
- 3.4 FACTORY ADJUSTMENT PARAMETERS

## 4 DESCRIPTION OF TERMINALS

- 4.1 ENCODER TERMINAL
- 4.2 COMMAND TERMINAL
- 4.3 ANALOG INPUT TERMINAL
- 4.4 DIGITAL INPUT TERMINAL
- 4.5 DIGITAL OUTPUT TERMINAL
- 4.6 ANALOG OUTPUT TERMINAL

## 5 MONITOR FUNCTION

- 5.1 OPERATING STATUS CHECK
- 5.2 TERMINAL STATUS CHECK
- 5.3 A/D CONVERTER CHECK

## 6 GENERAL OPERATION PARAMETERS

- 6.1 CONTROL and SPEED COMMAND SELECTION
- 6.2 MAIN SPEED & ACC/DEC TIME
- 6.3 BRAKING CHARACTERISTIC
- 6.4 FREQUENCY LIMIT, SKIP, V/F PATTERN, and CARRIER
- 6.5 JOG, SPD1, SPD2, and SPD3

## 7 AUXILIARY and MISCELLANEOUS

## 8 AUTO MODE PARAMETERS

## 9 RESTART SPEED SEARCH PROCESS

## 10 ERROR MESSAGE

## 11 COMPUTER CONTROL

## 12 ATTACHMENT DRAWING

## 1 LOCAL PANEL

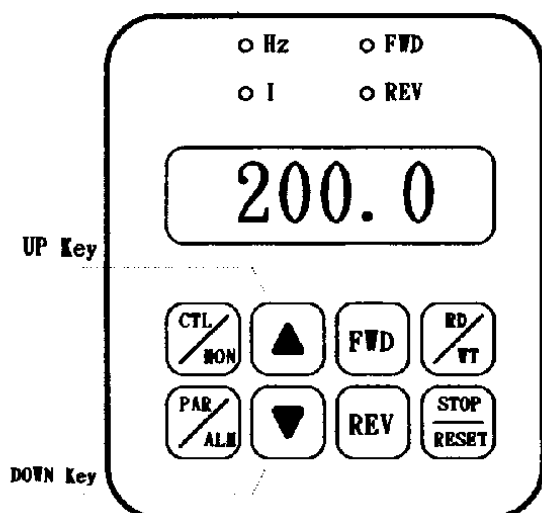

On LOCAL Panel there are four digit 7-segment data display and four indication led's and eight membrane keys. Four possible operation modes : "CTL", "MON", "PAR" and "ALM" are described follows :

### 1.1 CTL mode

Push the "CTL/MON" key, will toggle between "CTL" or "MON" Mode.

If both "HZ" and "I" Led are blank, it is under "CTL" Mode. Under "CTL" Mode, user can control the inverter running in either direction and may modify the desired running speed.

The key's functions are :

- FWD key is used for running the inverter in forward direction.
- REV key is used for running the inverter in reverse direction.
- STOP key is used to stop the inverter.
- RD/WT key has two function : READ from or WRITE to Pr.00.
- UP key is used to increase the set frequency or the data read from Pr.00.
- DN key is used to decrease the set frequency or the data read from Pr.00.

### 1.2 MON mode

Push the "CTL/MON" key, will toggle the inverter between "CTL" or "MON" Mode.

Under "MON" Mode, user can control the inverter running in either direction and may monitor any two internal status easily.(Refer to Sec.5)

If "HZ" Led is on, it is under "MON" Mode and 7-segment shows the "HZ" data.(Data assigned by Pr.99)

If "I" Led is on, it is under "MON"Mode and 7-segment shows the "I" data.(Data assigned by Pr.98)

- FWD key is used for running the inverter in forward direction.
- REV key is used for running the inverter in reverse direction.
- STOP key is used to the inverter.
- UP key is used to select "HZ" or "I" data shown on the 7-segment display.
- DN key is used to select "HZ" or "I" data shown on the 7-segment display.

### 1.3 PAR mode

Push the "PAR/ALM" key, will toggle between "PAR" or "ALM" mode.

If 7-segment shows "Pr.xx", it is under "PAR" Mode.

If 7-segment shows "0.-xx", it is under "ALM" Mode.

Under "PAR" Mode, user can modify or monitor all the internal PARAMETERS.To modify a parameter, follow the steps described below :

- STEP 1: push "PAR/ALM" key, the 7-segment will show "Pr.nn". (nn is parameter number)
- STEP 2: push "UP" or "DN" key to select desired parameter number.
- STEP 3: push "RD/WT" key to READ the content of the specified parameter. The 7-segment now shows the value of the parameter.
- STEP 4: push "UP" or "DN" key to modify the displayed value.
- STEP 5: push "RD/WT" key to WRITE the value into EAROM memory.
- STEP 6: push "PAR/ALM" repeat STEP 1.

## 1.4 ALM mode

Push the "PAR/ALM" key, will toggle the inverter between "PAR" or "ALM" mode.

If 7-segment shows "0.-xx", it is under "ALM" Mode.

Under "ALM" Mode, the user can execute RESET function or monitor ALARM STATUS.

STOP/RESET key, the inverter will execute RESET function.

UP and DN key are used to check ALARM History.

## 2 REMOTE PANEL

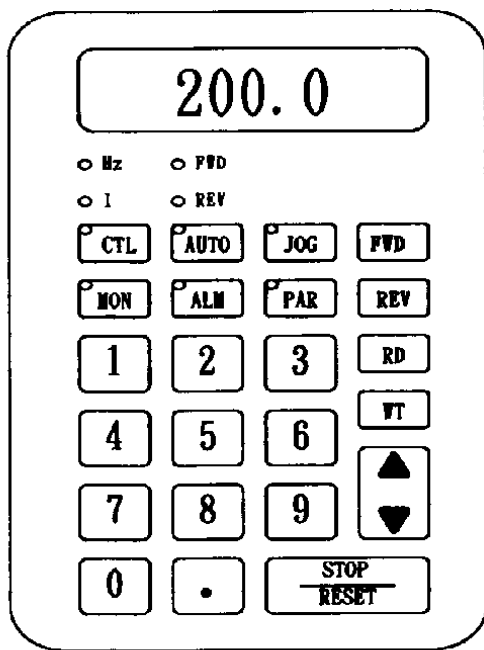

On REMOTE Panel there are four digit 7-segment data display, twelve indication led's and twenty-four membrane keys. It will operate under five possible modes: "CTL", "MON", "PAR", "JOG", and "ALM" modes.

Note: The "AUTO" key on REMOTE PANEL has no effect in PD-Series.

### 2.1 CTL mode

Push "CTL" key, the Remote Panel enters CONTROL mode immediately. Under "CTL" Mode, user can control the inverter running in either direction and may modify the

desired running speed. The key's functions are:

FWD key is used for running the inverter in forward direction.

REV key is used for running the inverter in reverse direction.

STOP key is used to stop the inverter.

RD key is used to READ the preset speed stored in Pr.00.

WT key is used to WRITE new desired speed into Pr.00.

Number & Decimal keys are used for modify the desired speed.

### 2.2 MON mode

Push "MON" key, the Remote Panel enters MONITOR mode immediately.

Under "MON" Mode, user can control the inverter running in either direction and may monitor any two internal status easily. (Refer to Sec. 5)

If "HZ" Led is on, 7-segment shows the "HZ" data (Data assigned by Pr.99)

If "I" Led is on, 7-segment shows the "I" data (Data assigned by Pr.98)

FWD key is used for running the inverter in forward direction.

REV key is used for running the inverter in reverse direction.

STOP key is used to stop the inverter.

UP/DN keys are used to select "HZ" or "I" data shown on the 7-segment display.

### 2.3 PAR mode

Push the "PAR" key, the Remote Panel enters PARAMETER mode immediately.

Under "PAR" Mode, user can modify or monitor all the internal PARAMETERS.

To modify a parameter, follow the steps described below:

STEP 1: Select Parameter & READ.

For example, to read Pr.19, operate as follows:

push "PAR", push "1", push "9", push "RD".

Then the content of Pr.19 will show on the 7-Segment display.

STEP 2: Modify parameter & WRITE.

Follow the example to write the value 15 into Pr.19.

Select Pr.19 as explained in STEP 1.

Push "1", push "5", push "WT".

Then the Pr.19 contains the value 15.

## 2.4 JOG mode

Push the "JOG" key, the Remote Panel enters JOG mode immediately.

FWD key is used to run the inverter in forward direction.

REV key is used to run the inverter in reverse direction.

If the FWD , REV key released, the inverter STOP.

## 2.5 ALM mode

Push the "ALM" key, the Remote Panel enters ALARM mode immediately.

STOP/RESET key is used to execute software RESET function.

UP/DN keys are used to check ALARM History .

## 3 PARAMETERS

### 3.1 PARAMETERS LIST

There are total 100 parameters in PD series inverter.

Pr.nn	PARAMETER NAME	DEFAULT VALUE	LOWER LIMIT	UPPER LIMIT	REFERENCE SECTION	STATUS
Pr.00	MAIN SPEED SET	60.00 HZ	0	200.00	Sec. 6.2	R/W *1
Pr.01	MAIN SPEED ACC	5.0 SEC	0.1	6553.0	Sec. 6.2	R/W
Pr.02	MAIN SPEED DEC	5.0 SEC	0.1	6553.0	Sec. 6.2	R/W
Pr.03	S CURVE ENABLE	0	0	1	Sec. 6.2	R/W
Pr.04	START HZ	1.50 HZ	0.50	30.00	Sec. 6.2	R/W
Pr.05	BRAKE HZ	5.00 HZ	0.50	200.00	Sec. 6.3	R/W
Pr.06	BRAKE VOLT%	3 %	0	30	Sec. 6.3	R/W *2
Pr.07	BRAKE TIME	1.0 SEC	0.0	25.0	Sec. 6.3	R/W
Pr.08	VOLTAGE DROP RATE	0.5 SEC	0.1	2.5	Sec. 6.3	R/W
Pr.09	BOOST VOLTAGE	3 %	0	30	Sec. 6.4	R/W *2
Pr.10	BASE HZ	60.00 HZ	0.50	200.00	Sec. 6.4	R/W
Pr.11	V/F PATTERN	0	0	250	Sec. 6.4	R/W
Pr.12	CARRIER	16.0 KHZ	2.0	16.0	Sec. 6.4	R/W
Pr.13	START CARRIER	2.0 KHZ	2.0	16.0	Sec. 6.4	R/W
Pr.14	TRANSFER POINT	1.5 HZ	0.00	200.00	Sec. 6.4	R/W
Pr.15	UPPER LIMIT	80.00 HZ	0.50	200.00	Sec. 6.4	R/W
Pr.16	LOWER LIMIT	1.50 HZ	0.50	200.00	Sec. 6.4	R/W
Pr.17	SKIP HZ	0.00 HZ	0.00	200.00	Sec. 6.4	R/W
Pr.18	SKIP WIDTH	0.00 HZ	0.00	5.00	Sec. 6.4	R/W
Pr.19	JOG HZ	10.00 HZ	0.50	200.00	Sec. 6.5	R/W
Pr.20	JOG ACC/DEC	5.0 SEC	0.1	25.0	Sec. 6.5	R/W
Pr.21	SPD1 SPEED SET	20.00 HZ	0.50	200.00	Sec. 6.5	R/W
Pr.22	SPD1 ACC TIME	5.0 SEC	0.1	6553.0	Sec. 6.5	R/W
Pr.23	SPD1 DEC TIME	5.0 SEC	0.1	6553.0	Sec. 6.5	R/W
Pr.24	SPD2 SPEED SET	60.00 HZ	0.50	200.00	Sec. 6.5	R/W
Pr.25	SPD2 ACC TIME	5.0 SEC	0.1	6553.0	Sec. 6.5	R/W
Pr.26	SPD2 DEC TIME	5.0 SEC	0.1	6553.0	Sec. 6.5	R/W
Pr.27	SPD3 SPEED SET	80.00 HZ	0.50	200.00	Sec. 6.5	R/W
Pr.28	SPD3 ACC TIME	5.0 SEC	0.1	6553.0	Sec. 6.5	R/W
Pr.29	SPD3 DEC TIME	5.0 SEC	0.1	6553.0	Sec. 6.5	R/W
Pr.30	FREE RUN STOP	0	0	1	Sec. 7.1	R/W
Pr.31	REVERSE INHIBIT	0	0	1	Sec. 7.2	R/W
Pr.32	AVR ENABLE	0	0	1	Sec. 7.3	R/W
Pr.33	DISCHARGE ENABLE	0	0	1	Sec. 7.4	R/W

Pr.nn	PARAMETER NAME	DEFAULT VALUE	LOWER LIMIT	UPPER LIMIT	REFERENCE SECTION	STATUS
Pr.34	UP/OP RESTART ENABLE	0	0	1	Sec. 7.5	R/W
Pr.35	STALL LEVEL	160 %	10	200	Sec. 7.6	R/W
Pr.36	BASE BLOCK TIME	0.5 SEC	0.1	5.0	Sec. 7.7	R/W
Pr.37	AM SELECT	0	0	3	Sec. 4.6	R/W
Pr.38	AM GAIN	255	0	255	Sec. 4.6	R/W
Pr.39	CMD SELECT	0	0	2	Sec. 4.2	R/W
Pr.40	SPEED SELECT	0	0	15	Sec. 4.3	R/W
Pr.41	DI1 ELECT	0	0	31	Sec. 4.4	R/W
Pr.42	DI2 SELECT	0	0	31	Sec. 4.4	R/W
Pr.43	DI3 SELECT	0	0	31	Sec. 4.4	R/W
Pr.44	DI4 SELECT	0	0	31	Sec. 4.4	R/W
Pr.45	DO1 SELECT	0	0	31	Sec. 4.5	R/W
Pr.46	DO2 SELECT	0	0	31	Sec. 4.5	R/W
Pr.47	RELAY SELECT	4	0	31	Sec. 4.5	R/W
Pr.48	DETECT IRMS	100 %	10	150	Sec. 7.8	R/W
Pr.49	DETECT HZ	30.00 HZ	0.00	200.00	Sec. 7.9	R/W
Pr.50	HZ TOLERANCE	5.0 HZ	0.00	25.0	Sec. 7.9	R/W
Pr.51	THERMAL TIME	60 SEC	0	120	Sec. 7.10	R/W
Pr.52	POLE	4	2	12	Sec. 7.11	R/W
Pr.53	GEAR RATIO	100 %	0	100	Sec. 7.11	R/W
Pr.54	IRMS SELECT	0	0	1	Sec. 7.12	R/W
Pr.55	AD SELECT	0	0	4	Sec. 5.3	R/W
Pr.56	AD DATA				Sec. 5.3	M *3
Pr.57	HZ				Sec. 5.1	M
Pr.58	RPM				Sec. 5.1	M
Pr.59	VDC INPUT				Sec. 5.1	M
Pr.60	VRMS				Sec. 5.1	M
Pr.61	IRMS				Sec. 5.1	M
Pr.62	DI1 INPUT STATUS		0	1	Sec. 5.2	M
Pr.63	DI2 INPUT STATUS		0	1	Sec. 5.2	M
Pr.64	DI3 INPUT STATUS		0	1	Sec. 5.2	M
Pr.65	DI4 INPUT STATUS		0	1	Sec. 5.2	M
Pr.66	RUN INPUT STATUS		0	1	Sec. 5.2	M
Pr.67	REV INPUT STATUS		0	1	Sec. 5.2	M
Pr.68	DO1 OUTPUT STATUS		0	1	Sec. 5.2	M
Pr.69	DO2 OUTPUT STATUS		0	1	Sec. 5.2	M
Pr.70	RELAY OUTPUT STATUS		0	1	Sec. 5.2	M
Pr.71	TIMER TIME	5.0 SEC	0.5	6553.0	Sec. 7.13	R/W
Pr.72	AUTO MODE SELECT	0	0	5	Sec. 8	R/W
Pr.73	AUTO STEP1(6) PERIOD	10.0 SEC	0.1	6553.0	Sec. 8	R/W
Pr.74	AUTO STEP2(7)PERIOD	10.0 SEC	0.1	6553.0	Sec. 8	R/W
Pr.75	AUTO STEP3(8) PERIOD	10.0 SEC	0.1	6553.0	Sec. 8	R/W
Pr.76	AUTO STEP4(9) PERIOD	10.0 SEC	0.1	6553.0	Sec. 8	R/W
Pr.77	AUTO STEP5(10) PERIOD	10.0 SEC	0.1	6553.0	Sec. 8	R/W
Pr.78	MOTOR RATING	100 %	10	100	Sec. 7.10	R/W
Pr.79	RESTART TYPE SELECT	0	0	3	Sec. 9	R/W
Pr.80	RESTART STALL LEVEL	100%	10	200	Sec. 9	R/W
Pr.81	SPEED SEARCH DEC TIME	2.0 SEC	0.1	25.0	Sec. 9	R/W

Pr.nn	PARAMETER NAME	DEFAULT VALUE	LOWER LIMIT	UPPER LIMIT	REFERENCE SECTION	STATUS
Pr.82	VOLTAGE RECOVER TIME	0.5 SEC	0.1	5.0	Sec. 9	R/W
Pr.83	PWM TRANSFER LEVEL	20%	10	86	Sec. 3.4	FR/W *4
Pr.84	LINE VOLTAGE		40	1000	Sec. 3.4	FR/W *4
Pr.85	RATED CURRENT		0.5	3000.0	Sec. 3.4	FR/W *4
Pr.86	IRMS ADJUST		70	140	Sec. 3.4	FR/W *4
Pr.87	VDC ADJUST		70	140	Sec. 3.4	FR/W *4
Pr.88	COMPENSATION	0.8us	0.0	25.0	Sec. 3.4	FR/W
Pr.89	AI1 LOW	12	0	1023	Sec. 3.4	FR/W
Pr/90	AI1 HIGH	1012	0	1023	Sec. 3.4	FR/W
Pr.91	AI2 LOW	12	0	1023	Sec. 3.4	FR/W
Pr.92	AI2 HIGH	1012	0	1023	Sec. 3.4	FR/W
Pr.93	UNIT NUMBER	1	1	99	Sec. 3.4, & 11	FR/W
Pr.94	RELOAD	0	0	1	Sec. 3.3	R/W
Pr.95	MEMORY PROTECT	0	0	1	Sec. 3.2	R/W
Pr.96	FACTORY WRITE ENABLE	0	0	1	Sec. 3.2	R/W
Pr.97	VERSION		0.00	99.99		*5
Pr.98	MONITOR(I)	61	0	99	Sec. 5	R/W
Pr.99	MONITOR(HZ)	57	0	99	Sec. 5	R/W

- Note :
1. R/W read and write , protect by Pr.95
  2. After V4.27~ the default value of BRAKE VOLT and BOOST VOLTAGE changed to 3%.
  3. M read only for monitor purpose
  4. FR/W read and write , protect by Pr.95 & Pr.96.  
Default value may be changed according to factory adjustment results.
  5. CPU revision code.

### 3.2 PARAMETER PROTECTION

Relative parameters :

Pr.95 -- MEMORY PROTECT

Pr.96 -- FACTORY WRITE ENABLE

There are two parameters for memory protection use.

Pr.95 is used for general protection.

Pr.96 is used to protect a special group of memory from Pr.83 to Pr.93., which should not be written by un-authorized people.

Pr.95	Pr.96	FUNCTION
0	0	ENABLE WRITE (exclude Pr.83 -- Pr.93)
0	1	ENABLE WRITE (include Pr.83 -- Pr.93)
1	X	DISABLE WRITE
1	X	DISABLE WRITE

X: don't care

### 3.3 PARAMETERS RELOAD

Pr.94 is used to RELOAD data into those memories marked with "R/W" STATUS.

Follow the process to RELOAD

Step 1 : Write Pr.94 = 1

Step 2 : Execute "ALM" RESET (Refer to Sec. 1.4 & Sec.2.5)

or Step 2 : Execute Hardware RESET (Refer to Sec. 4.7)

or Step 2 : Execute Power-On RESET

After reload process, the data in memory will change to the DEFAULT values listed in the PARAMETERS LIST Table.

### 3.4 FACTORY ADJUSTMENT PARAMETERS

From Pr.83 to Pr.93 are factory adjustment parameters.

Unless Customer is fully familiar with the PD series inverter, please refrain from changing these parameters.

PARAMETER	FUNCTION
Pr.83	PWM TRANSFER LEVEL
Pr.84	LINE VOLTAGE
Pr.85	RATED CURRENT
Pr.86	IRMS ADJUST
Pr.87	VDC ADJUST
Pr.88	IGBT COMPENSATION
Pr.89	AI1 LOW
Pr.90	AI1 HIGH
Pr.91	AI2 LOW
Pr.92	AI2 HIGH
Pr.93	UNIT NUMBER

#### Pr.83 : PWM TRANSFER LEVEL

The PD-Series inverter uses both 2\_PHASE and 3\_PHASE PWM Modulation method.

The CPU will transfer between those two methods depending on the output voltage level.

If OUTPUT VOLTAGE LEVEL (%) > Pr.83, then inverter will select 2\_PHASE PWM Modulation.

If OUTPUT VOLTAGE LEVEL (%) < Pr.83-5%, then inverter will select 3\_PHASE PWM Modulation.

#### Pr.84 : LINE\_VOLTAGE

This parameter defines the normal working voltage of the inverter.

According to this parameter, the inverter calculates all voltage dependent values.

- a. OP Trip Voltage (VDC) =  $1.414 * Pr.84 * 130\%$
- b. UP trip Voltage (VDC) =  $1.414 * Pr.84 * 70\%$
- c. OP Recover Voltage (VDC) =  $1.414 * Pr.84 * 120\%$
- d. UP Recover Voltage (VDC) =  $1.414 * Pr.84 * 80\%$
- e. Contact On Voltage (VDC) =  $1.414 * Pr.84 * 69\%$
- f. Contact Off Voltage (VDC) =  $1.414 * Pr.84 * 65\%$

Note : The "Contact" means the device used to BY-PASS the Charging Resistor.

It may be a RELAY or a SCR instead.

- g. Discharge Start Voltage (VDC) =  $1.414 * Pr.84 * 115\%$  (Sec. 7.4)

- h. Full Discharge Voltage (VDC) =  $1.414 * Pr.84 * 125\%$

Note : If the "VDC" is between 115% ~ 125%, the duty cycle of the Discharge circuit is proportionall to the voltage level.

#### Pr.85 : RATED\_CURRENT

This parameter defines the rated output current of the inverter.

#### Pr.86 : IRMS\_ADJUST

This parameter is used to adjust the IRMS data reading.

#### Pr.87 : VDC\_ADJUST

This parameter is used to adjust the VDC data reading.

#### Pr.88 : IGBT\_COMPENSATION

This parameter is used to compensate IGBT timing.

#### Pr.89 : AI1\_LOW

This parameter is used to record the A/D converter data when "AI1" input terminal is connected to "ACOM" terminal.(JP1 select +10V)



**Pr.90 : AI1\_HIGH**

This parameter is used to record the A/D converter data when "AI1" input terminal is connected to "+10V" voltage source.(JP1 select +10V)

**Pr.91 : AI2\_LOW**

This parameter is used to record the A/D converter data when "AI2" input terminal is connected to "ACOM" terminal.(JP2 select +5V)

**Pr.92 : AI2\_HIGH**

This parameter is used to record the A/D converter data when "AI2" input terminal is connected to "+5V" terminal.(JP2 select +5V)

**Pr.93 : UNIT\_NUMBER**

This parameter is used to assign the ADDRESS NUMBER of this INVERTER UNIT while controlled by master computer through RS485 interface.

**4. DESCRIPTION OF TERMINALS (Refer to Drawing in Sec.12.1)**

CHB	PG+	AI1	ACOM	AI2	DI1	DI2	REV	24V	D01	D02
-----	-----	-----	------	-----	-----	-----	-----	-----	-----	-----

CHA	PG-	AM	5V	DI3	DI4	RST	RUN	DCOM	RY1	RY2
-----	-----	----	----	-----	-----	-----	-----	------	-----	-----

**4.1 ENCODER TERMINAL(PG+, PG-, CHA & CHB)**

*Four terminals "PG+", "PG-", "CHA" and "CHB" are build in for feedback control system*

*Only used in "JPS-PDF" series.*

**4.2 COMMAND TERMINAL(RUN, REV & DCOM)**

This section describes the function of "RUN" & "REV". The input terminals will be ACTIVE if they are connected to "DCOM" terminal.

Relative parameter :

**Pr.39 -- CMD\_SELECT**

The value in Pr.39 assigns the definition of these terminals.

**Pr.39=0**

The "RUN" & "REV" terminals are disabled. Control Command must come from PANEL directly.

**Pr.39=1**

The "RUN" terminal starts the inverter, & "REV" terminal determines the direction.

**Pr.39=2**

The "RUN" terminal is equivalent to FORWARD-RUN.

The "REV" terminal is equivalent to REVERSE-RUN.

Pr.39	"RUN" Terminal	"REV" Terminal	FUNCTION
0	don't care	don't care	Command from PANEL
1	OFF	don't care	STOP
	OFF	don't care	STOP
	ON	OFF	FORWARD RUN
	ON	ON	REVERSE RUN
2	OFF	OFF	STOP
	OFF	ON	REVERSE RUN
	ON	don't care	FORWARD RUN

### 4.3 ANALOG INPUT TERMINAL( +5V, AI1, AI2 & ACOM)

This section describes the function of "+5V", "AI1", "AI2" & "ACOM" terminals.

Relative parameters:

Pr.40 -- SPD\_SELECT

Hardware Jumpers

JP1 : Select jumper for AI1. May select -5V~+5V(Default) or 0~+10V.

JP2 : Select jumper for AI2. May select 0~+5V(Default) or 20mA.

Both "AI1" and "AI2" terminals are used for Analog Speed Inputs.

Refer to the following table, Use Pr.40 & JP1, JP2, the inverter provides various operation configurations.

Pr.40	JP1	JP2	SPEED source	DIRECTION Source
0	don't care	don't care	Value in Pr.00 *1	From Command
1	+ 10V	don't care	AI1 Uni-directional	From Command
2	don't care	+ 5V(or 20mA)	AI2 Uni-directional	From Command
3	don't care	don't care	Set value from Panel	From Command
4	+/- 5V	don't care	AI1 Bi-directional *2	By AI1 input value
5	don't care	+ 5V(or 20mA)	AI2 Bi-directional	By AI2 input value
6	don't care	don't care	By U/D counter	From Command
7	Similar to Pr.40=6, but will preload U/D counter from Pr.00 after RESET.			
8	Similar to Pr.40=3, but will preload Panel Set value from Pr.00 after RESET.			
9	Similar to Pr.40=4, but will not STOP while desired frequency is low *3			
10	Similar to Pr.40=5, but will not STOP while desired frequency is low			

\*1 : Refer to Drawing in Sec. 12.2 .

\*2 : Relationship between AI1 input signal & Hz output, while Pr.40=4

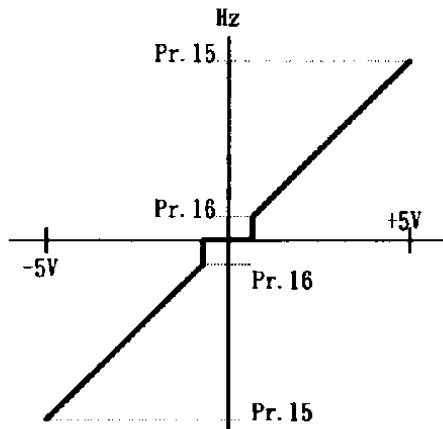

\*3 : Relationship between AI1 input signal & Hz output, while Pr.40=9

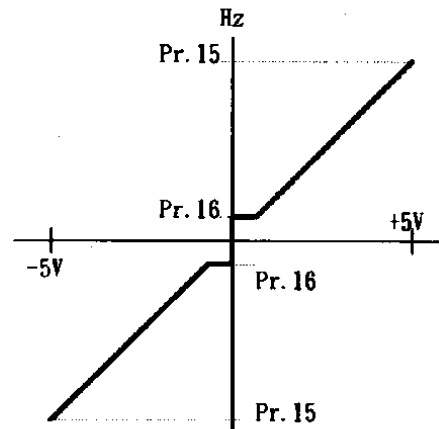

### 4.4 DIGITAL INPUT TERMINAL(DI1, DI2, DI3, DI4 & DCOM)

This section describes the function of "DI1", "DI2", "DI3", & "DI4" terminals. These terminals are all identical DIGITAL INPUT terminals. They will be ACTIVE when connected to "DCOM".

These terminals are all designed as multi-functional digital input terminal. Each input terminal can be configured individually by DIx\_SELECT parameters.

Relative parameters :

Pr.41 -- DI1\_SELECT

Pr.42 -- DI2\_SELECT

Pr.43 -- DI3\_SELECT

Pr.44 -- DI4\_SELECT

Each input can select one of the following special functions individually.

Pr.41,42,43,44	FUNCTION	COMMENT	NOTE
0	NULL	NO FUNCTION	
1	EMS	EMERGENCY STOP	Sec. 6.3
2	SPD3	SPEED SET	Sec. 6.5
3	SPD2	SPEED SET	Sec. 6.5
4	SPD1	SPEED SET	Sec. 6.5
5	JOG	JOG SPEED SET	Sec. 6.5
6	OH	OVER HEAT	*1
7	TMIA	TIMER INPUT TYPE A	Sec. 7.13
8	ON_BB	BASE BLOCK if DIx is ON	Sec. 9
9	FJR	FORWARD JOG RUN	Sec. 6.5
10	RJR	REVERSE JOG RUN	Sec. 6.5
11	TMIB	TIMER INPUT TYPE B	Sec. 7.13
12	SAVE	SAVE ENERGY	*2
13	UP	INCREASE UP/DOWN COUNTER	*3
14	DOWN	DECREASE UP/ DOWN COUNTER	*3
15	U/D CLEAR	CLEAR UP/DOWN COUNTER	*3
16	U/D SET	SET Pr.15 to UP/DOWN COUNTER	*4
17	U/D HOLD	HOLD "Output HZ" to UP/DOWN COUNTER	*4
18	OFF_BB	BASE BLOCK if DIx is ON	Sec. 9, *5
19 <sup>21</sup>	ALARM CLEAR	CLEAR ALARM WHEN ALARM OCCUR	
20 <sup>19</sup>	UP	INCREASE UP/DOWN COUNTER	*6
21 <sup>20</sup>	DOWN	DECREASE UP/DOWN COUNTER	*6

- \*1. If the Input active, will cause inverter TRIP & show "OH" alarm.
- \*2. While DIx select SAVE function, OUTPUT VOLTAGE will decrease 20%.
- \*3. If Pr.40 = 6, Speed source is from INTERNAL UP/DOWN COUNTER,  
If "UP" terminal active, the COUNTER increases at 4.00Hz/Second rate.  
If "DOWN" terminal active, the COUNTER decreases at 4.00Hz/Second rate.  
If "CLEAR" terminal active, the COUNTER clear immediately.
- \*4. This function is available after V4.16~.  
If "SET" terminal active, the COUNTER will be load from Pr. 15, the UPPER\_LIMIT Frequency.  
If "HOLD" terminal is active, the COUNTER will be load from present running "HZ".
- \*5. This function is available after V4.16~.  
This function is similar to DIx=8, but "BB" function is effective if DIx is OFF.
- \*6. This function is available after V4.22~.  
This function is similar to DIx=13 and DIx=14, but the increase/decrease rate are according to Pr.01(main speed acceleration time) and Pr.02(main speed deceleration time).

#### 4.5 DIGITAL OUTPUT TERMINAL( +24V, DO1, DO2, and RY1 , RY2 )

Relative parameters :

- Pr.45 -- DO1\_SELECT
- Pr.46 -- DO2\_SELECT
- Pr.47 -- RELAY\_SELECT

The "DO1", "DO2", "RY1,RY2" terminals are multinational DIGITAL OUTPUTS.

The circuit structure of "DO1" & "DO2" are Transistor OPEN COLLECTOR outputs.

The "RY1" & "RY2" terminals are NORMAL OPEN contacts of the output RELAY .

Any of the above three outputs may configured into one of the following output functions :

Pr. 45,46,47	FUNCTION	COMMENT	NOTE
0	NULL	NO FUNCTION	
1	NOT RUN	NOT RUNNING	*1
2	SPE	SPEED EQUAL	Sec. 7.9
3	SPNE	SPEED NOT EQUAL	Sec. 7.9
4	ALM	ALARM	Sec. 10
5	NALM	NO ALARM	Sec. 10
6	BRAKING	UNDER BRAKING	Sec. 6.3
7	RUNNING	UNDER RUNNING	*1
8	SPO	SPEED OVER	Sec. 7.9
9	SPNO	SPEED NOT OVER	Sec. 7.9
10	SPA	SPEED ARRIVE	*2
11	SPNA	SPEED NOT ARRIVE	*2
12	DIR	OUTPUT DIRECTION	*3
13	COD	CURRENT OVER DETECT	Sec. 7.8
14	TMOA	TIMER OUTPUT TYPE A	Sec. 7.13
15	SPZ	ZERO SPEED	Sec. 7.9
16	SPNZ	NOT ZERO SPEED	Sec. 7.9
17	STALLING	OUTPUT WHILE STALLING	*4
18	SLOW ACC	ACC TIME EXTENSION	*5
19	SLOW DEC	DEC TIME EXTENSION	*6
20	TMOB	TIMER OUTPUT TYPE B	Sec. 7.13
21	STEP1	AUTO RUNNING AT STEP 1	Sec. 8.2
22	STEP2	AUTO RUNNING AT STEP 2	Sec. 8.2
23	STEP3	AUTO RUNNING AT STEP 3	Sec. 8.2
24	STEP4	AUTO RUNNING AT STEP 4	Sec. 8.2
25	STEP5	AUTO RUNNING AT STEP 5	Sec. 8.2
26	STEP6	AUTO RUNNING AT STEP 6	Sec. 8.2
27	STEP7	AUTO RUNNING AT STEP 7	Sec. 8.2
28	STEP8	AUTO RUNNING AT STEP 8	Sec. 8.2
29	STEP9	AUTO RUNNING AT STEP 9	Sec. 8.2
30	STEP10	AUTO RUNNING AT STEP 10	Sec. 8.2
31	RESERVE		*7

- \*1. Status output indicating inverter is RUNNING or NOT RUNNING.
- \*2. Status output indicating the output HZ is equal to desire frequency SET.
- \*3. Indicating the phase direction of output waveform.
- \*4. Indicating the status of STALL while IRMS > Pr.35(STALL LEVEL)
- \*5. Indicating the inverter is modifying the ACC RATE, due to some internal limitation is over.
- \*6. Indicating the inverter is modifying the DEC RATE, due to some internal limitation is over.
- \*7. Reserve function for factory test use.

#### 4.6 ANALOG OUTPUT TERMINAL( AM & ACOM )

This section describes the definition of analog output voltage between "AM" & "ACOM".

Relative parameter

Pr.37 -- AM\_SELECT

Pr.38 -- AM\_GAIN

Auxiliary Analog Output Terminal "AM" is provided for analog meter display, or other applications requiring the analog output signal.

"AM\_SELECT" is used to select desired signal output.

"AM\_GAIN" is used to fine tuning the output voltage level.

User may select any of the four signals in the Table for output to the "AM" terminal.

Pr.37	AM Terminal Function
0	HZ Signal
1	IRMS Signal
2	VDC Signal
3	VOOUT Signal

#### 4.7 RESET TERMINAL ( RST & DCOM )

If " RST " terminal connected to " DGND ", then Inverter will execute hardware RESET immediately.

#### 5 MONITOR FUNCTION

While Panel is in MON mode, user can select which two status are to be monitored.

Pr.98 is used to assign the parameter to be monitored, when "I" LED is on.

Pr.99 is used to assign the parameter to be monitored, when "HZ" LED is on.

For example, the default value in Pr.99 is 57. That means, 7-segment will display the value of Pr.57 while "HZ" LED is on.

#### 5.1 OPERATING STATUS CHECK

Parameters from Pr.57 ~ Pr.61 are inverter running status for user monitoring purpose.

Pr.57 HZ

HZ status shows the running frequency.

Pr.58 RPM

RPM status is calculated by HZ status. Refer to Section 7, description of Pr.52 & Pr.53.

Pr.59 VDC

VDC is the DC voltage measured from internal Smoothing Capacitor.

Pr.60 OUTPUT\_VOLTAGE

OUTPUT\_VOLTAGE is the Root-Mean-Square value of inverter output voltage.

Pr.61 IRMS

IRMS is the Root-Mean-Square value of inverter output current.

#### 5.2 TERMINAL STATUS CHECK

User can easily check the input or output terminal status from following parameters :

TERMINAL STATUS is easily verified by select the corresponding parameter number.

PARAMETER	TERMINAL STATUS
Pr.62	DI1 STATUS
Pr.63	DI2 STATUS
Pr.64	DI3 STATUS
Pr.65	DI4 STATUS
Pr.66	RUN STATUS
Pr.67	REV STATUS
Pr.68	DO1 STATUS
Pr.69	DO2 STATUS
Pr.70	RELAY STATUS

#### 5.3 A/D CONVERTER CHECK

Pr.55 AD\_SELECT

Pr.56 AD\_DATA

The PD Series inverter can monitor 5 analog input signals.

Use Pr.55 to select the desired channel to read, then Pr.56 will contain the A/D value of the corresponding channel.

The range of the converted data is between 0 to 1023.

Pr.55	Pr.56 (AD DATA)
0	VDC channel A/D value
1	IU channel A/D value
2	IV channel A/D value
3	AI1 channel A/D value
4	AI2 channel A/D value

## 6 GENERAL OPERATION PARAMETERS

### 6.1 CONTROL and SPEED COMMAND SELECTION

#### Pr.39 COMMAND\_SELECT

This parameter determines the command source whether from PANEL or from TERMINAL.  
Refer to Section 4.2

#### Pr.40 SPEED\_SELECT

This parameter determines the speed source. Refer to Section 4.3 .

### 6.2 MAIN SPEED & ACC/DEC TIME

#### Pr.00 MAIN\_SPEED\_SET

Pr.00 is the Main Speed memorized in EAROM.

If SPD\_SELECT(Pr.40)=0, this MAIN\_SPEED\_SET parameter will be used as the desired frequency source.

Note : while the Panel is in"CTL" mode, READ or WRITE will always points to this parameter.

#### Pr.01 MAIN\_ACC\_TIME

#### Pr.02 MAIN\_DEC\_TIME

Pr.01 & Pr.02 are the preset ACC & DEC time while inverter running.

#### Pr.03 S\_CURVE ENABLE

S\_CURVE parameter is used for applications requiring more soft acceleration and deceleration.  
Time constant for S\_CURVE is 0.64 second.

#### Pr.04 START\_FREQUENCY

Inverter will start if the input speed command is greater than this parameter and Pr.16(Lower limit).  
Refer to Section 6.4, description of Pr.16 .

### 6.3 BRAKING CHARACTERISTIC PARAMETERS

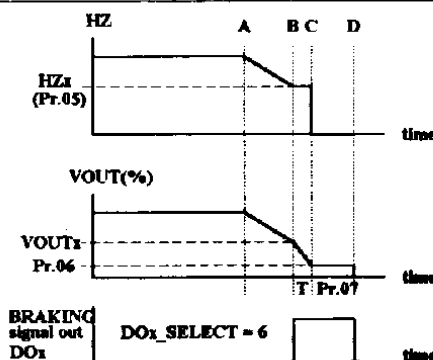

TIMING RELATIONSHIP BETWEEN HZ & VOUT WHILE BRAKING STOP

NOTE : A. The time when "STOP" signal input.  
B. The time when output HZ = Pr.05  
or the time when "EMS" is active.  
C. The time when VOUT equal Pr.06.  
D. The time when Pr.07 time is complete.  
T. The time during "Voltage Drop" .  
 $T = (VOUTx - Pr.06) \cdot Pr.08$

#### Pr.05 BRAKE FREQUENCY

While deceleration, if the output frequency is lower than this parameter , then DC Dynamic braking starts.

#### Pr.06 BRAKE VOLTAGE

While braking starts, this parameter defines the DC injection level.

#### Pr.07 BRAKE TIME

This parameter defines the braking time.

#### Pr.08 VOLTAGE DROP RATE

While deceleration, if output frequency is lower than braking frequency(Pr.05), the output voltage will first drop down to the brake voltage(Pr.06) before DC injection starts. This parameter is defined as the drop time required from rated voltage down to zero.

## 6.4 FREQUENCY LIMIT, SKIP, V/F PATTERN, and CARRIER

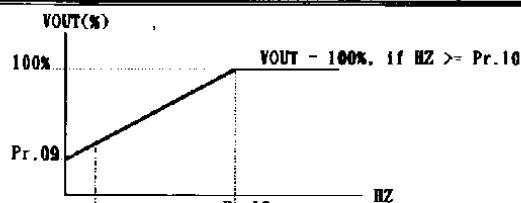

Pr.09 BOOST  
Pr.10 BASE\_FREQUENCY  
Pr.11 V/F PATTERN

if HZ < Pr.10,  
VOUT = a + b \* X + c \* X \* X  
where : a = Pr.09(%)  
b = ( 1 - Pr.11 / 255 ) \* ( 100% - Pr.09 )  
c = ( Pr.11 / 255 ) \* ( 100% - Pr.09 )  
X = HZ / Pr.10

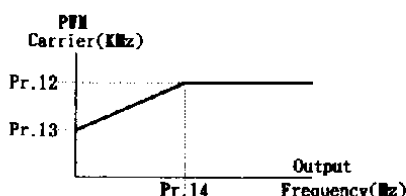

Pr.12 PWM\_CARRIER  
Pr.13 MINIMUM\_CARRIER  
Pr.14 CARRIER\_TRANSFER\_POINT

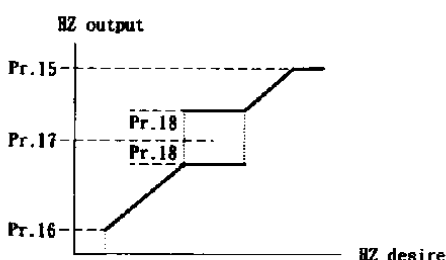

Pr.15 UPPER\_FREQUENCY\_LIMIT  
Pr.16 LOWER\_FREQUENCY\_LIMIT  
Pr.17 SKIP\_FREQUENCY  
Pr.18 SKIP\_BAND

## 6.5 JOG, SPD1, SPD2, and SPD3

While using REMOTE PANEL, it is possible to JOG-RUN the inverter through the "JOG", "FWD" & "REV" keys. When applications use only LOCAL PANEL & Terminals to control the inverter, multi-function inputs DIx may serve the function.

Refer to Sec. 4.4, By using DIx\_SELECT parameters, up to four predefined SPEED & ACC/DEC rate can be selected easily.

Note 1 : The priority level is JOG > SPD1 > SPD2 > SPD3 > MAIN SPEED.

MAIN SPEED stands for the speed set from Pr.00, or Panel, or UP/DOWN counter, or AIx.

Note 2 : Normally the JOG, SPD1, SPD2, & SPD3 functions must be combined with RUN Command.

Note 3 : Special function "FJR" will force the inverter "Forward-Jog-Run" without RUN Command.

Note 4 : Special function "RJR" will force the inverter "Reverse-Jog-Run" without RUN Command.

PARAMETER	FUNCTION	COMMENT
Pr.19	JOG FREQUENCY	Desired JOG Frequency
Pr.20	JOG ACC/DEC TIME	ACC/DEC rate when select JOG
Pr.21	SPD1 FREQUENCY	Desire SPD1 Frequency
Pr.22	SPD1 ACC TIME	ACC rate when select SPD1
Pr.23	SPD1 DEC TIME	DEC rate when select SPD1
Pr.24	SPD2 FREQUENCY	Desire SPD2 Frequency
Pr.25	SPD2 ACC TIME	ACC rate when select SPD2
Pr.26	SPD2 DEC TIME	DEC rate when select SPD2
Pr.27	SPD3 FREQUENCY	Desire SPD3 Frequency
Pr.28	SPD3 ACC TIME	ACC rate when select SPD3
Pr.29	SPD3 DEC TIME	DEC rate when select SPD3

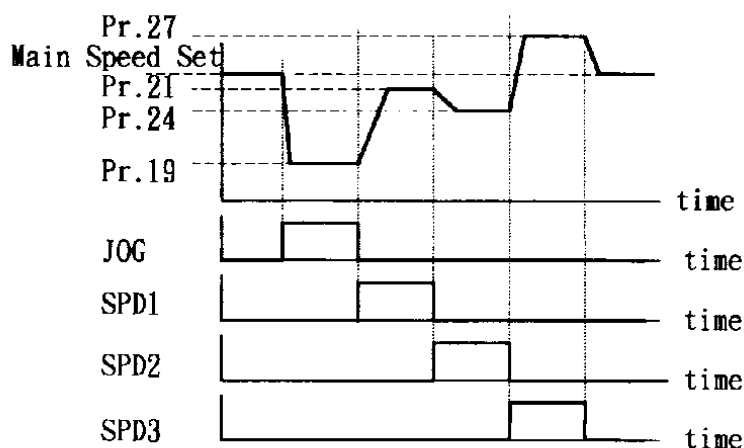

## 7 AUXILIARY and MISCELLANEOUS PARAMETERS

### 7.1 STOP METHOD SELECT

#### Pr.30 FREE RUN STOP

If Pr.30 = 0, Inverter stops the motor by decreasing output frequency.

If Pr.30 = 1, Inverter disables output immediately, the motor free run.

### 7.2 REVERSE RUN INHIBITION

#### Pr.31 REVERSE\_INH

If Pr.31 = 0, Inverter may run in both direction.

If Pr.31 = 1, Reverse Run is inhibited.

### 7.3 AUTOMATIC OUTPUT VOLTAGE CONTROL

#### Pr.32 AVR\_ENABLE

Pr.32 = 1, Select "Automatic Voltage Regulation" of the inverter output voltage.

### 7.4 DISCHARGE CIRCUIT ENABLE FOR DYNAMIC BRAKE

#### Pr.33 DISCHARGE\_ENABLE

If Pr.33 = 1, Discharge circuit is Enabled.

When VDC voltage on capacitor is too high, the energy stored in capacitor will be discharged through discharge resistor.

Instead of Hysteresis Bang-Bang control, the Discharge operation is duty-cycle controlled depending on the VDC level.

Refer to Section 3.4, description of Pr.84.

### 7.5 RESTART CONTROL AFTER UP/OP TRIP

#### Pr.34 UP/OP RESTART\_ENABLE

If Pr.34 = 1, Inverter will restart automatically, after power come back normal.

### 7.6 OVER LOAD STALL PREVENTION

#### Pr.35 STALL\_LEVEL

This parameter defines the current limit level(%) while STALL process.

### 7.7 BASE BLOCK CONTROL

#### Pr.36 BASE BLOCK TIME

This parameter defines the minimum stop time while executing BASE BLOCK function or when ALARM occurs.



## 7.8 DETECT LEVEL FOR "COD" FUNCTION(Current Over Detection)

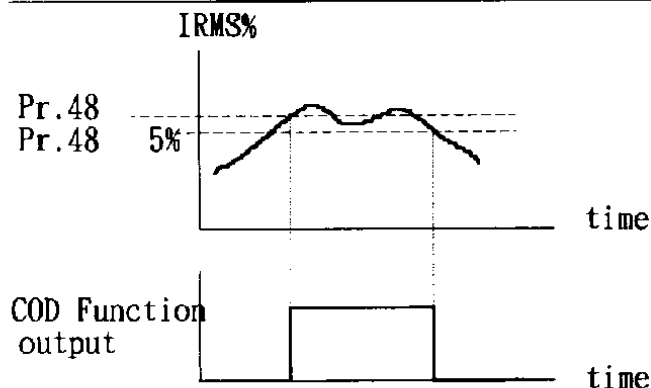

### Pr.48 DETECT IRMS

Refer to section 4.5.

Pr.48 serves as the threshold value when digital output select the COD function.

If output current IRMS(%) > Pr.48, then COD function active. After COD function is active, it may be cleared if IRMS(%) < (Pr.48 - 5%).

## 7.9 OUTPUT FREQUENCY DETECTION

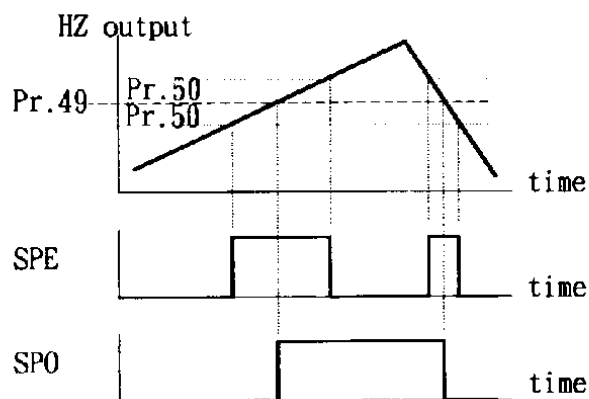

### Pr.49 DETECT HZ

Refer to Section 4.5.

Pr.49 serves as the threshold value when digital output select the SPE, SPNE, SPO, or SPNO function.

### Pr.50 HZ TOLERANCE

Pr.50 serves as the allowable detection tolerance of Pr.49.

## 7.10 ELECTRONIC THERMAL RELAY

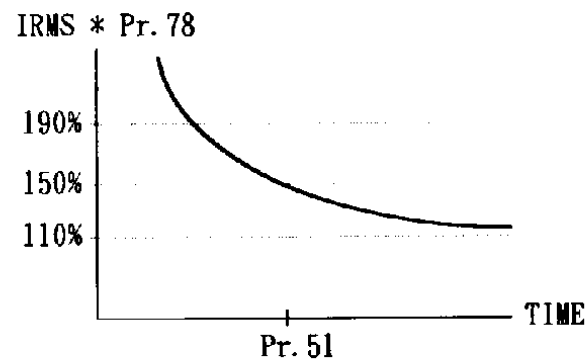

### Pr.51 THERMAL\_TIME

This parameter defines the OVER LOAD trip time of the INTERNAL THERMAL RELAY. If Pr.51=0, the THERMAL RELAY function is disabled.

### Pr.78 MOTOR RATING

If the inverter's rating capacity is larger than the motor in use, this parameter can be adjusted to protect the motor. This parameter is defined as the percentage level of the inverter rating.

## 7.11 RPM CALCULATION

Pr.52 POLE

Pr.53 GEAR\_RATIO

Pole & Gear\_Ratio parameters will be used for RPM(Pr.58) calculation.

$$\text{RPM} = (120 * \text{HZ} / \text{POLE}) * \text{GEAR\_RATIO}\%$$

## 7.12 IRMS DISPLAY TYPE SELECTION

Pr.54 IRMS\_SELECT

If Pr.54 = 0, IRMS(Pr.61) is expressed in AMPERE

If Pr.54 = 1, IRMS(Pr.61) is expressed in PERCENTAGE.

## 7.13 TIMER FUNCTION

### Pr.71 TIMER\_TIME

TIMER\_TIME parameter is used While TMIA(or TMIB) & TMOA(or TMOB) functions are selected for Digital I/O.

Refer to Section 4.4 & 4.5 .

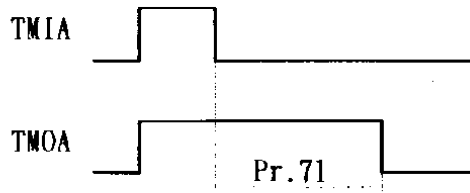

#### 7.13.1 Timer Type A : ( OFF-DELAY Timer )

If TMIA input terminal is ON(active), then TMOA terminal will be active immediately. After MIA is OFF, the TMOA terminal will still remain in active state for the time period defined in this parameter.

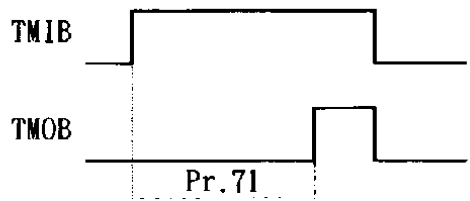

#### 7.13.2 Timer Type B : ( ON-DELAY Timer )

If TMIB input terminal is ON and continuous ON , Then the TMOB terminal will go active after the time period defined in this parameter. If TMIB is OFF, then TMOB will OFF immediately.

## 8 AUTO MODE

Note : The "AUTO" key on REMOTE PANEL has no effect in PD series.

### 8.1 AUTO MODE SELECTION & RUNNING

TABLE OF PARAMETERS USED FOR AUTO MODE.

PARAMETER	FUNCTION
Pr.72	AUTO MODE SELECT
Pr.73	JOG PERIOD TIME
Pr.74	SPD1 PERIOD TIME
Pr.75	SPD2 PERIOD TIME
Pr.76	SPD3 PERIOD TIME
Pr.77	HALT PERIOD TIME

TABLE OF AUTO MODE FUNCTIONS

Pr.72	AUTO FUNCTION DESCRIPTION
0	NO AUTO FUNCTION
1	STEP RUN & MAINTAIN SPEED
2	STEP RUN , STOP & REPEAT
3	STEP RUN , STOP & CHANGE DIRECTION REPEAT
4	STEP RUN , & REPEAT
5	STEP RUN , & CHANGE DIRECTION REPEAT

#### Pr.72 = 1 STEP RUN & MAINTAIN

- STEP1 inverter running as if JOG command is applied. time is determined by Pr.73(JOG\_PERIOD).
- STEP2 inverter running as if SPD1 command is applied. time is determined by Pr.74(SPD1\_PERIOD).
- STEP3 inverter running as if SPD2 command is applied. time is determined by Pr.75(SPD2\_PERIOD).
- STEP4 inverter running as if SPD3 command is applied. time is determined by Pr.76(SPD3\_PERIOD).
- STEP5 inverter running at specified MAIN speed as if it is in normal mode.

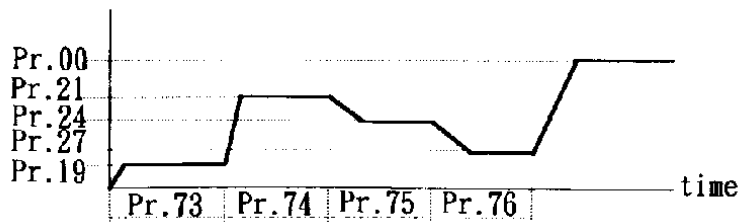

Example speed pattern of AUTO STEP RUN Type 1

Pr.72 = 2 STEP RUN , STOP & REPEAT

- STEP1 inverter running as if JOG command is applied.  
time is determined by Pr.73(JOG\_PERIOD).
  - STEP2 inverter running as if SPD1 command is applied.  
time is determined by Pr.74( SPD1\_PERIOD).
  - STEP3 inverter running as if SPD2 command is applied.  
time is determined by Pr.75( SPD2\_PERIOD).
  - STEP4 inverter running as if SPD3 command is applied.  
time is determined by Pr.76( SPD3\_PERIOD).
  - STEP5 inverter running as if STOP command is applied.  
time is determined by Pr.77(HALT\_PERIOD).
- AFTER STEP5, REPEAT FROM STEP1.

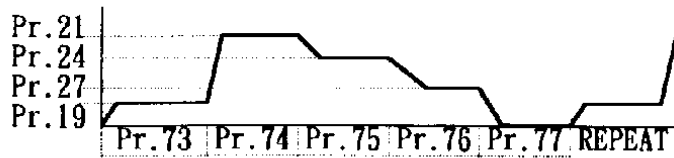

Example speed pattern of AUTO STEP RUN Type 2

Pr.72 = 3 STEP RUN , STOP & CHANGE DIRECTION REPEAT

- STEP1 inverter running as if JOG command is applied.  
time is determined by Pr.73(JOG\_PERIOD).
  - STEP2 inverter running as if SPD1 command is applied.  
time is determined by Pr.74( SPD1\_PERIOD).
  - STEP3 inverter running as if SPD2 command is applied.  
time is determined by Pr.75( SPD2\_PERIOD).
  - STEP4 inverter running as if SPD3 command is applied.  
time is determined by Pr.76( SPD3\_PERIOD).
  - STEP5 inverter running as if STOP command is applied.  
time is determined by Pr.77(HALT\_PERIOD).
- AFTER STEP5, CHANGE DIRECTION
- STEP6 inverter running as if JOG command is applied.  
time is determined by Pr.73(JOG\_PERIOD).
  - STEP7 inverter running as if SPD1 command is applied.  
time is determined by Pr.74( SPD1\_PERIOD).
  - STEP8 inverter running as if SPD2 command is applied.  
time is determined by Pr.75( SPD2\_PERIOD).
  - STEP9 inverter running as if SPD3 command is applied.  
time is determined by Pr.76( SPD3\_PERIOD).
  - STEP10 inverter running as if STOP command is applied.  
time is determined by Pr.77(HALT\_PERIOD).
- AFTER STEP10, REPEAT FROM STEP1.

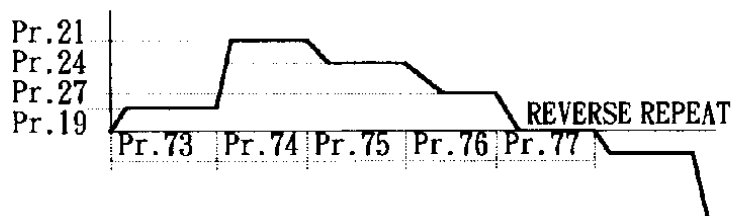

Example speed pattern of AUTO STEP RUN Type 3

**Pr.72 = 4 STEP RUN & REPEAT**

This mode is similar to mode2.

From STEP1 to STEP4, its operation is exactly the same as mode2.

Under STEP5 period, the inverter will run at MAIN speed instead of STOP command.

AFTER STEP5, REPEAT FROM STEP1.

**Pr.72 = 5 STEP RUN & CHANGE DIRECTION REPEAT**

This mode is similar to mode3.

From STEP1 to STEP4, its operation is exactly the same as mode3.

Under STEP5 period, the inverter will run at MAIN speed instead of STOP command.

From STEP6 to STEP9, its operation is exactly the same as mode3.

Under STEP10 period, the inverter will run at MAIN speed instead of STOP command.

AFTER STEP10, REPEAT FROM STEP1.

**8.2 AUTO STEP EQUAL OUTPUT**

During AUTO RUNNING , there are special DOx functions reserved for AUTO STEP EQUAL application.

EXAMPLE :

If user wishes to activate the DOx outputs when inverter is auto running ,

if LET DO1\_SELECT(Pr.45) = 22, select STEP2

DO2\_SELECT(Pr.46) = 23, select STEP3

RELAY\_SELECT(Pr.47) = 24, select STEP4

THEN DO1 terminal will become active, while the inverter is running at STEP2

DO2 terminal will become active, while the inverter is running at STEP3

RELAY terminals will become active, while the inverter is running at STEP4

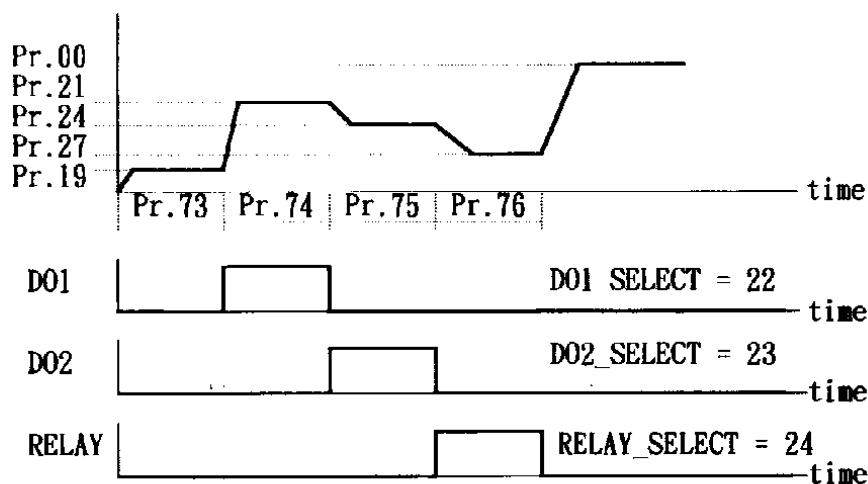

EXAMPLE Timing Relationship waveform of "STEP EQUAL OUTPUT " Function.

**9 RESTART SPEED SEARCH PROCESS**

Pr.79 to Pr.82 are used to define the inverter's speed searching characteristics for restart process.

The Speed Search function may be initiated by two methods :

### 1. Digital Input

LET DI<sub>x</sub>\_SELECT=8, selects "Base Block" input function.

If terminal DI<sub>x</sub> is active, then the inverter will disable IGBT output causing the motor FREE RUN.

When DI<sub>x</sub> inactive again, the inverter will still remain in the BLOCK state for a period of time defined in the parameter STOP TIME(Pr.36).

After the period of STOP TIME, Then the restart process begins.

### 2. UP/OP restart

LET Pr.34 = 1, enables UP/OP restart function.

If "UP" or "OP" alarm appear while inverter running, Then the inverter will disable IGBT output causing the motor FREE RUN.

When Power come back to normal again, the inverter will still remain in the BLOCK state for a period of time defined in the parameter STOP TIME(Pr.36).

After the period of STOP TIME, Then the restart process begins.

PARAMETER	FUNCTION	DESCRIPTION
Pr.79	RESTART TYPE	SELECT RESTART TYPE
Pr.80	RESTART STALL LEVEL	STALL LEVEL WHILE RESTARTING
Pr.81	RESTART DEC TIME	DEC TIME WHILE SPEED SEARCH
Pr.82	VOLTAGE RECOVER TIME	VOLTAGE INCREASING RATE WHILE RESTARTING

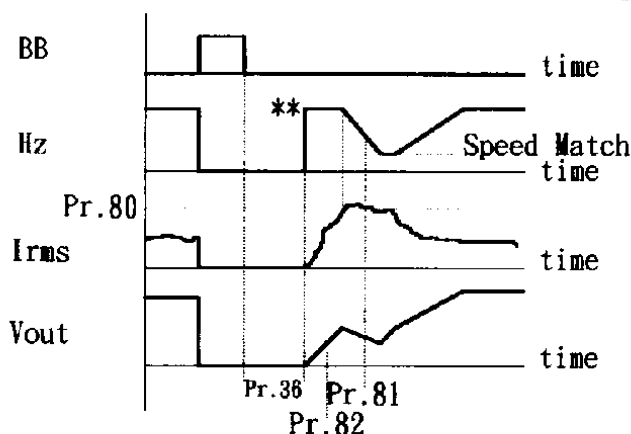

- Pr.79 = 0 No restart speed search process. Inverter will start from low speed.
- Pr.79 = 1 Speed search begins from previous running frequency.
- Pr.79 = 2 Speed search begins from UPPER LIMIT frequency(Pr.15).
- Pr.79 = 3 Speed search begins from SET SPEED.

\*\* Note: The search start frequency is selected by Pr.79

## 10 ERROR MESSAGE

ERROR CODE	MESSAGE DESCRIPTION
n. --	NO ALARM
n. OP	OVER VOLTAGE
n. UP	UNDER VOLTAGE
n. OL	OVER LOAD
n. OH	OVER HEAT
n. OC	OVER CURRENT when normal run
n. CA	OC when acceleration
n. CD	OC when deceleration
n. CB	OC when braking
n. CS	OC detect by Software
E-SP	Serial Port communication Error (REMOTE PANEL only)

Note: n=0, present alarm type.  
 n=1, alarm type before.  
 n=2, alarm type twice before.  
 n=3, alarm type three times before.

## 11 COMPUTER CONTROL

The PD Series Inverter has a built in RS-485 communication port on CON3 of CPU-Board. CON3 is a 5-pin connector. The definition of all the connector pins are :

- Pin 1 : +5V
- Pin 2 : 0V
- Pin 3 : SIG+
- Pin 4 : SIG-
- Pin 5 : RESET OUTPUT(NOT USED BY COMPUTER)

### PROTOCOL & FORMAT

Baud Rate : 4800, 7 Bit data, Even parity, 1 Stop Bit.

Each PD-Series inverter has a pre-assigned UNIT ADDRESS in Pr.97. Computer may control any Inverter unit by select its corresponding UNIT ADDRESS.

Furthermore, the Computer may control all Inverter units at the same time if the "uu" code in command string is "00".

#### *Computer to Inverter*

Computer may send three types of message to Inverter

Control Command :(No response will send back from Inverter)

"C,uu,cc,ffff"

C : Head of COMMAND String

uu : unit number, from 00 to 99

Note : When uu = 00, all inverter unit must accept.

cc : control command code, from 00 to 99

The "cc" number is actually converted from four bits binary data,

$cc = 8 * \text{Bit-3} + 4 * \text{Bit-2} + 2 * \text{Bit-1} + \text{Bit-0}$

Bit-0 : RESET INVERTER

Bit-1 : RUN

Bit-2 : REVERSE

Bit-3 : JOG

ffff : set frequency, from 00000 to 20000, representing desired Hz = 0.00 to 200.00Hz.

Write Command :(No response will send back from Inverter)

"W,uu,nn,dddd"

W : Head of WRITE String

uu : unit number, from 00 to 99

Note : When uu = 00, all inverter unit must accept.

nn : parameter number, from 00 to 99

dddd : data value, from 00000 to 65535

Read Command :(Inverter will send back P-String after receive this string)

"R,uu,nn"

R : Head of READ String

uu : unit number, from 00 to 99

Note : When uu = 00, all inverter unit must accept.

Do not specify uu=00 for R-String while multiple inverters are under control.

nn : parameter number, from 00 to 99

## *Inverter to Computer*

### Parameter & Status Response( Response to Computer for R-string)

"P,uu,nn,tt,dddd,s,aaaa"

**P** : P stands for PARAMETER String

**uu** : unit number, from 00 to 99.

This number is defined in Pr.97.

**nn** : parameter number, from 00 to 99

**tt** : data type of this parameter, from 00 to 15

tt = 00 : data WORD from EAROM, format 999.99.

tt = 01 : data WORD from EAROM, format 9999.9

tt = 02 : data WORD from EAROM, format 99999

tt = 03 : data BYTE from EAROM, format 999.99

tt = 04 : data BYTE from EAROM, format 9999.9

tt = 05 : data BYTE from EAROM, format 99999

tt = 06 : data BIT from EAROM, format 99999

tt = 07 : data from CPU memory, format 99999

tt = 08 : signed data from CPU memory. format +/-999.99

If followed data <32768, the data is valid and positive.

Else the data is negative, which is -(65536-ddddd).

tt = 09 : data WORD from CPU memory, format 999.99

tt = 10 : data WORD from CPU memory, format 9999.9

tt = 11 : data WORD from CPU memory, format 99999

tt = 12 : data BYTE from CPU memory, format 999.99

tt = 13 : data BYTE from CPU memory, format 9999.9

tt = 14 : data BYTE from CPU memory, format 99999

tt = 15 : data BIT from CPU memory, format 99999

Note : Only those parameters with type 00~07 may write by COMPUTER.

**dddd** : data value, from 00000 to 65535

**s** : inverter output status, from 0 to 9

s = 1 : INVERTER REVERSE RUNNING

s = 2 : INVERTER FORWARD RUNNING

s = 3 : INVERTER STOP

else , undefined

**aaaa** : alarm history, from 0000 to 9999

The PD-Series inverter may record 4 Error messages.

Most significant digit stands for oldest error message.

Least significant digit stands for present error message.

a = 0 : No alarm

a = 1 : CA Over Current when acceleration

a = 2 : CD Over Current when deceleration

a = 3 : OC Over Current when not acceleration or deceleration.

a = 4 : OH Over Heat

a = 5 : OP Over Potential

a = 6 : UP Under Potential

a = 7 : OL Over Load

a = 8 : CB Over Current when DC Braking

a = 9 : CS 200% Over Current detected by Software

# 12 ATTACHMENT DRAWINGS

## 12.1 STANDARD WIRING DIAGRAM

### JPS-PD/PDF SERIES INVERTER

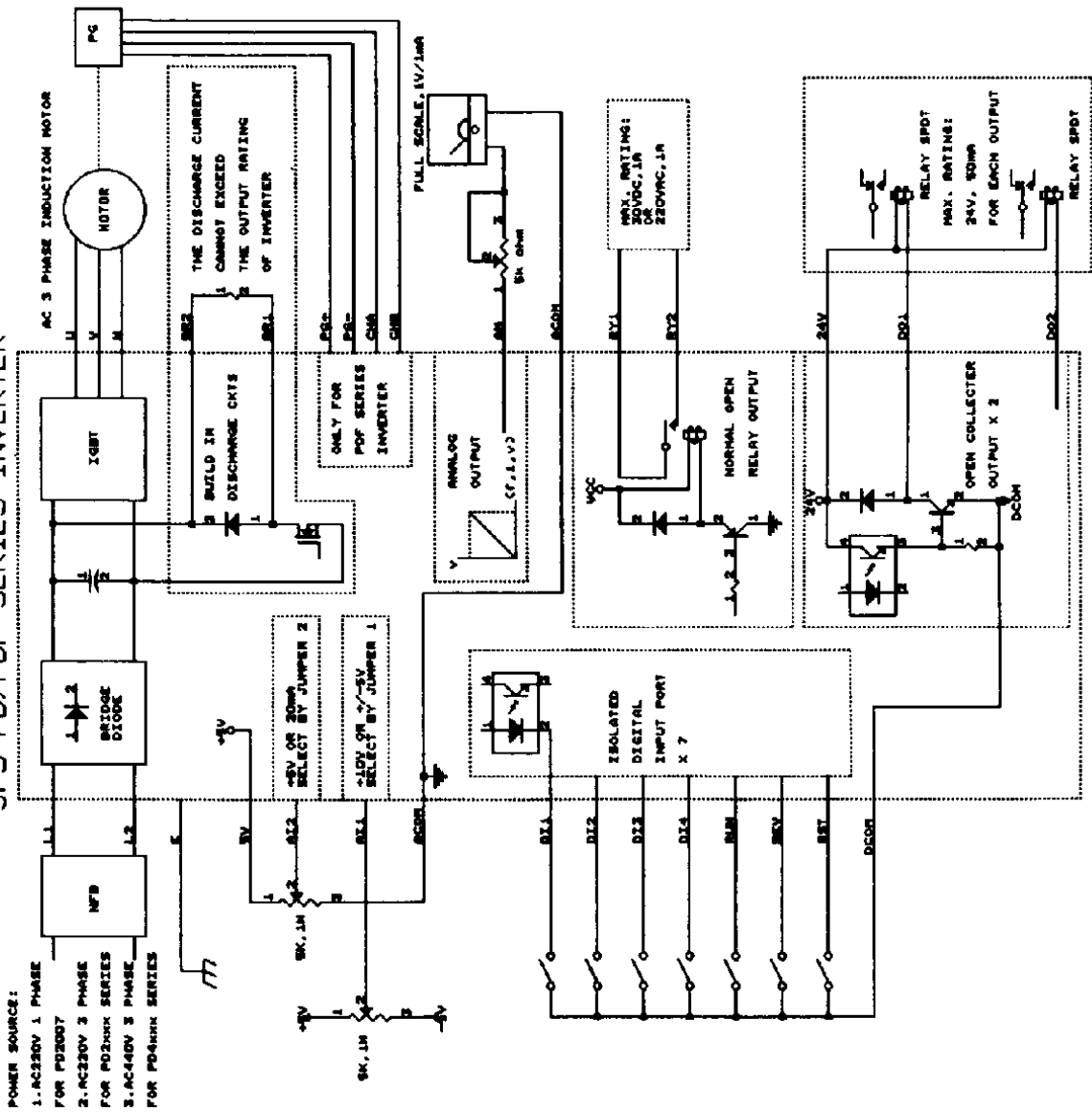

JOINT PEER SYSTEC CORP.  
 TITLE: STANDARD WIRING DIAGRAM FOR PD/PDF INVERTER  
 DRAWING NUMBER: PDW-SCH  
 DATE: FEBRUARY 1978



# 12.2 BLOCK DIAGRAM OF PR.40(SPD SELECT) FUNCTION

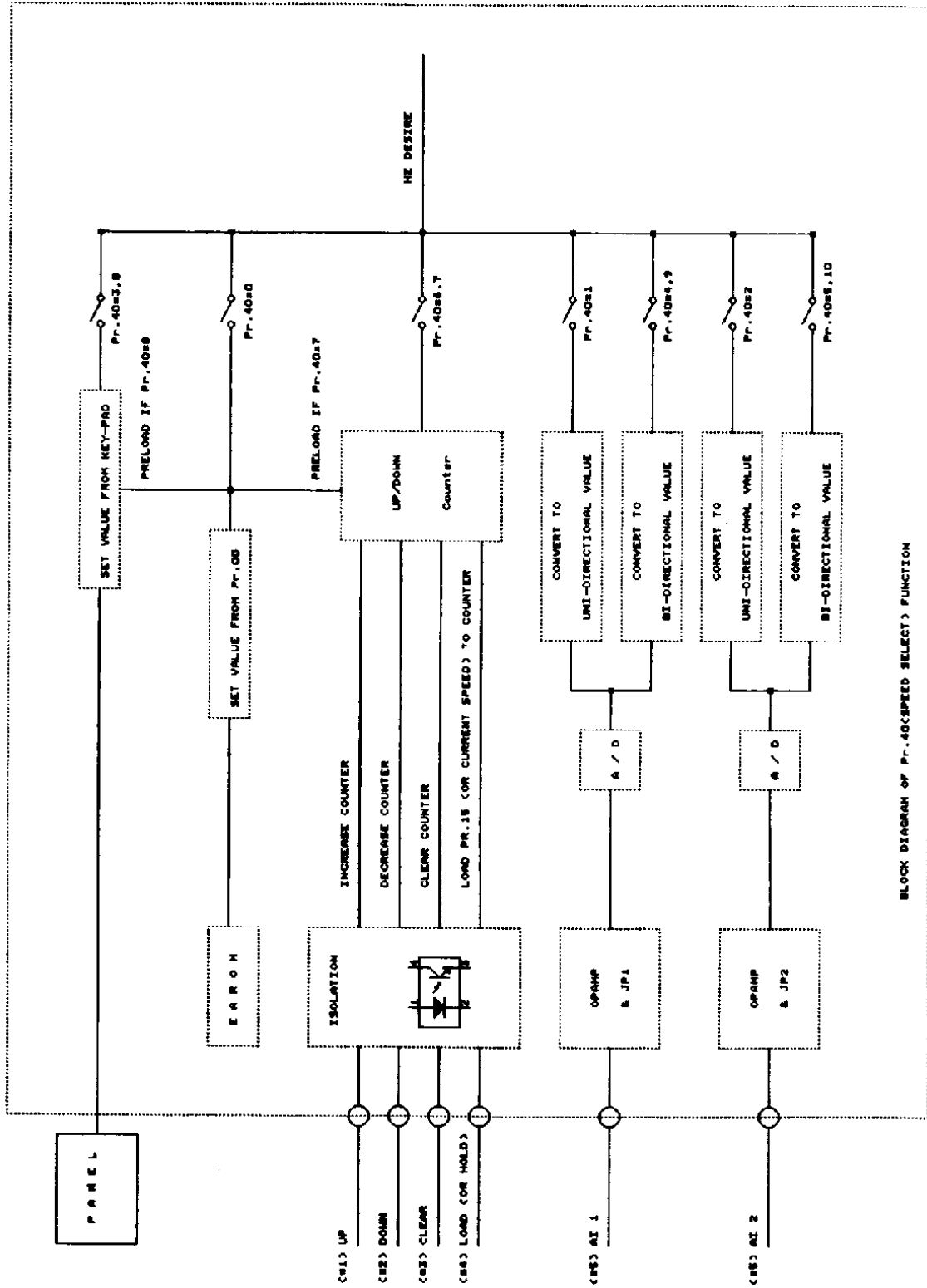

BLOCK DIAGRAM OF PR.40(SPEED SELECT) FUNCTION

- R1 : DIGITAL INPUT TERMINAL "DIR", LET DIR\_SELECT=13, OR 20.
- R2 : DIGITAL INPUT TERMINAL "DIR", LET DIR\_SELECT=14, OR 21.
- R3 : DIGITAL INPUT TERMINAL "DIR", LET DIR\_SELECT=15.
- R4 : DIGITAL INPUT TERMINAL "DIR", LET DIR\_SELECT=16, OR 17.
- R5 : ANALOG INPUT TERMINAL.

TITLE	JOINT PEER SYSTEC COMP.
SIZE	PD CPU CONTROL BLOCK
REV	01
FILE	HW 23 1981 BETA

## UPDATE INFORMATION FOR THE PD-SERIES CPU FUNCTION

The standard instruction manual that we released before is valid only up to V4.27. Now we release V4.75 with following modifications.

### 1. NEW FUNCTION

#### 1.1 Internal Flip/Flop function ( available after V4.65 )

Two Flip/Flops were build in for new DI/DO function.

Each Flip/Flop block has two SET inputs, two CLEAR inputs and two complement outputs.

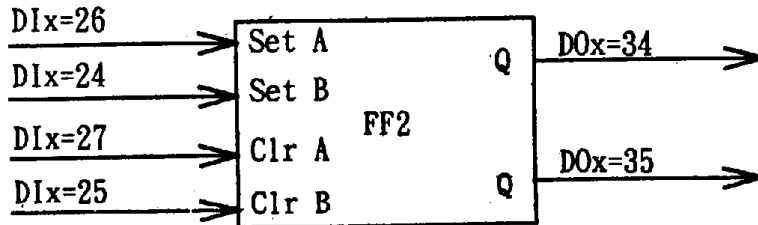
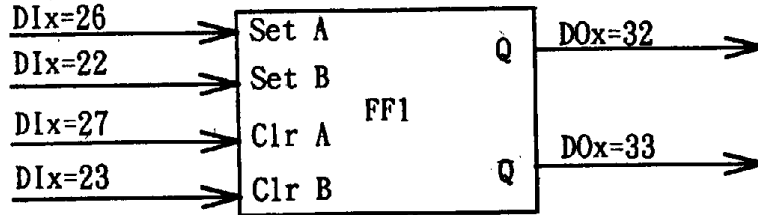

Note :

For example, if DI1 and DI2 are used to SET and CLEAR the FF1 respectively, then Let DI1\_Select(Pr.41) = 22 and DI2\_Select(Pr.42) = 23.

And if the output of FF1 is assigned to DO1, then Let DO1\_Select(Pr.45) = 32.

For digital input function if DIx=26, will SET both FF1 & FF2.

For digital input function if DIx=27, will CLR both FF1 & FF2.

#### 1.2 Modify the internal "Timer Block" into "Timer/Counter Block"

Before version V4.33, there exist an internal timer block.

After V4.33, the timer block is modified to "Timer/Counter Block".

If counter function is desired, just select any digital input( DIx) to serve as the clock input terminal, and let the corresponding parameter(DIx\_Select) set to 28.

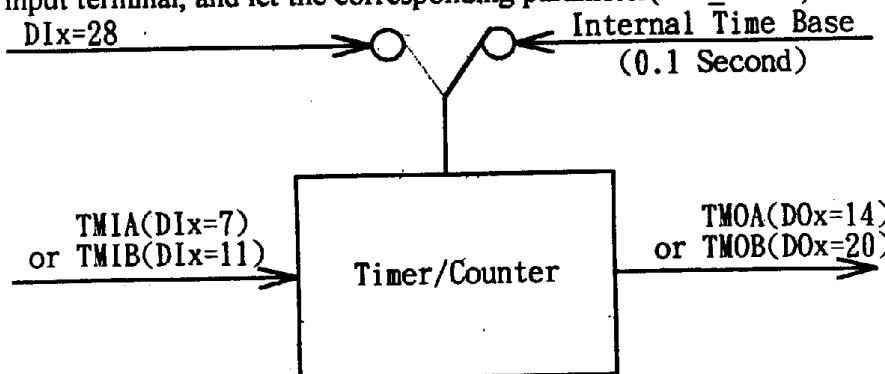

Note :

The maximum clock input rate is 100Hz.

There is only one internal Timer/Counter Block, you can use only one Timer/Counter, either TYPE A or TYPE B.

### **1.3 More Speed Source Select function**

#### **1.3.1 Pr.40 = 11 (V4.67~)**

The Speed source will come from UP/DOWN counter.

This mode is similar to type 6,

except : if push DOWN continuously, the speed will only decrease down to "LOW LIMIT FREQUENCY(assigned by Pr.16)".

#### **1.3.2 Pr.40 = 12 (V4.69~)**

The speed input come from AI1 \* AI2.

AI1 serves as main speed input set.

AI2 serves as proportional gain, 0~ 5V stands for 0~100% gain.

#### **1.3.3 Pr.40 = 13 (V4.69~)**

The speed input come from AI2 + AI1.

AI2 serves as main speed input set.

AI1 serves as minor speed modification, it may be + or - signal.

Please set JP1 to +/- 5V location.

### **1.4 OTHER IMPROVEMENT**

#### **1.4.1 Auto Write to Pr.00 ( V4.69~ )**

If you are using LOCAL panel(8 key type) under mode Pr.40 = 8, after you modify the desired frequency by "UP" or "DOWN" key, the inverter will load the new value into Pr.00 automatically.

In this way, next time you power on the inverter, it will start from the new value stored in Pr.00.

#### **1.4.2 Digital Output always ON function(V4.71~)**

If DOx\_Select = 38, then the corresponding DOx will be active.

This function may be used for testing, or while you are using Computer control, it serves as an computer controllerable output.

Note : DOx\_Select = 0 is NULL function(always inactive).

DOx\_Select = 36, 37 are reserved.

#### **1.4.3 Special Case for Memory Protect(V4.74~)**

Under Pr.40 = 3 or 8 , Pr.00 is allow to change even if Pr.95 = 1.

#### **1.4.4 More function on AM terminal(V4.75)**

If AM\_Select (Pr.37) = 5, the voltage output from "AM" terminal is protional to the internal UP/DOWN counter.

### **2. PARAMETER DEFAULT VALUE CHANGES**

#### **2.1 Default Values for Speed Set Parameters(V4.63~)**

Pr.00, Pr.21, Pr.24 & Pr.27 have change their default values to 0.00Hz.

Pr.14 change to 10.00Hz.

#### **2.2 Default values for ACC and DEC Time(V4.63)**

Pr.01, Pr.02, Pr.20, Pr.22, Pr.23, Pr.25, Pr.26, Pr.28, & Pr.29 all change the default value to 10.0 Seconds.

#### **2.3 Default Values for Auto Run Timing(V4.63)**

Pr.73, Pr.74, Pr.75, Pr.76 & Pr.77 all change the default value to 15.0 Seconds.

#### **2.4 Default Value for Speed\_Select(V4.73~)**

Default value for Pr.40 = 8.

### **3. PARAMETER DEFINITION CHANGES**

#### **3.1 Cancel PWM\_SELECT function(V4.65~)**

The PWM pattern always select Two Phase Modulation method. Therefore, the PWM\_Select function is cancelled. And Pr.83 is not for this function.

### **3.2 DeadTime Assignment(V4.54)**

The Deadtime is assigned by Pr.83.

This parameter is used for factory production adjustment.

Customer is not allowed to change this parameter.

### **3.3 DeadTime Compensation(V4.64)**

The deadtime compensation is always enabled.

The compensation value will be trimmed to best condition automatically.

Therefore, Pr.88 is deleted , and has no effect at all.

Note :

The "DeadTime" is the guard time necessary for preventing the IGBT damage.

However, the deadtime will cause vibration of motor especially at low frequency.

Therefore, compensation is necessary to improve the vibration problem.

### **3.4 Parameter Type Change(V4.58~)**

Pr.12, Pr.13 & Pr.14 change to Factory protect type.

\*\*\*\* In Sec.4.4 of previous Instruction Manual, please change as follows :

DIx=19, UP function

DIx=20, DOWN function

DIx=21, ALARM CLEAR

\*\*\*\* In Sec.11, there are two mistakes about the "UNIT ADDRESS",

Actually, the unit address is assigned by Pr.93, not by Pr.97.

# **POWER DRIVE SERVICES**

**Electric Motor Control Specialists**

**Unit 1, Victoria St. Ind. Est.  
Victoria Street, LEIGH  
Greater Manchester WN7 5SE U.K.  
Tel +44 (0)1942 260206 Fax +44 (0)1942 260325**

